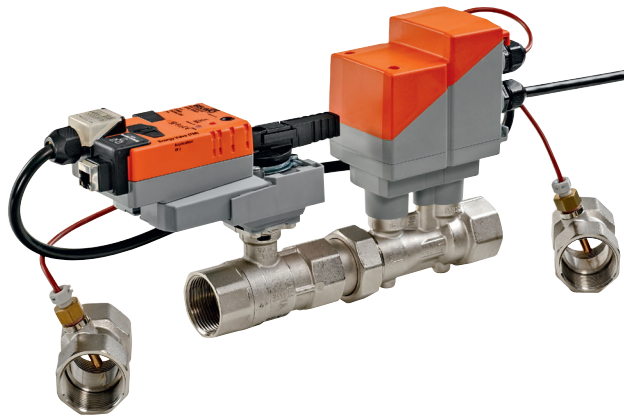

Characterised control valve with sensor-operated flow rate or power control, power and energy-monitoring function, 2-way, Internal thread, PN 16 (Energy Valve)

- Nominal voltage AC/DC 24 V
- Control modulating, communicative, hybrid
- For closed cold and warm water systems
- For modulating control of air-handling and heating systems on the water side
- Ethernet 10/100 Mbit/s, TCP/IP, integrated web server
- Communication via BACnet, Modbus, Belimo MP-Bus or conventional control
- optional Belimo Cloud connection
- Glycol monitoring

Type overview

Type	DN []	Rp ["]	Vnom [l/s]	Vnom [l/min]	kvs theor. [m³/h]	PN []	n(gl) []
EV015R+BAC1	15	1/2	0.35	21	2.9	16	3.2
EV020R+BAC1	20	3/4	0.65	39	4.9	16	3.2
EV025R+BAC1	25	1	1.15	69	8.6	16	3.2
EV032R+BAC1	32	1 1/4	1.8	108	14.2	16	3.2
EV040R+BAC1	40	1 1/2	2.5	150	21.3	16	3.2
EV050R+BAC1	50	2	4.8	288	32.0	16	3.2

kvs theor.: Theoretical kvs value for pressure drop calculation

Technical data

Electrical data	Nominal voltage	AC/DC 24 V
	Nominal voltage frequency	50/60 Hz
	Nominal voltage range	AC 19.2...28.8 V / DC 21.6...28.8 V
	Power consumption in operation	4 W (DN 15...25) 5 W (DN 32...50)
	Power consumption at rest	3.7W (DN 15...25) 3.9W (DN 32...50)
	Power consumption for wire sizing	6.5 VA (DN 15...25) 7.5 VA (DN 32...50)
	Connection supply / control	Cable 1 m, 6 x 0.75 mm ²
	Connection control Ethernet	RJ45 socket
	Parallel operation	Yes (note the performance data)
	Functional data	Torque motor
Communicative control		BACnet IP, BACnet MS/TP Modbus TCP, Modbus RTU MP-Bus
Operating range Y		DC 2...10 V
Input Impedance		100 kΩ
Operating range Y variable		DC 0.5...10 V
Position feedback U		DC 2...10 V
Position feedback U note		Max. 1 mA
Position feedback U variable		DC 0...10 V DC 0.5...10 V
Sound power level motor		35 dB(A) (DN 15...40) 45 dB(A) (DN 50)
Adjustable flow rate Vmax		30...100% of Vnom
Control accuracy		±10% (of 25...100% Vnom)
Control accuracy note		±6% (of 25...100% Vnom) @ 20 °C / Glycol 0% vol.

Technical data

Functional data	Configuration	via integrated web server / ZTH EU	
	Media	Cold and warm water, water with glycol up to max. 50% vol.	
	Medium temperature	-10...120 °C	
	Permissible pressure ps	1600 kPa	
	Closing pressure Δp_s	1400 kPa	
	Differential pressure Δp_{max}	350 kPa	
	Differential pressure note	200 kPa for low-noise operation	
	Flow characteristic	equal percentage (VDI/VDE 2178), optimised in the opening range (switchable to linear)	
	Leakage rate	Leakage rate A, air-bubble-tight (EN 12266-1)	
	Installation position	Upright to horizontal (in relation to the stem)	
	Maintenance	Maintenance-free	
	Manual override	with push-button, can be locked	
	Flow measurement	Measuring principle	Ultrasonic volumetric flow measurement
		Flow measuring accuracy	$\pm 6\%$ (of 25...100% Vnom)
Note on flow measuring accuracy		$\pm 2\%$ (of 25...100% Vnom) @ 20 °C / Glycol 0% vol.	
Min. flow measurement		1% of Vnom	
Temperature measurement	Measuring accuracy of the absolute temperature	$\pm 0.6\text{ °C}$ @ 60 °C (PT1000 EN60751 Class B)	
	Measuring accuracy of temperature difference	$\pm 0.23\text{ K}$ @ $\Delta T = 20\text{ K}$	
	Resolution	0.05 °C	
Glycolmonitoring	Measurement display glycol	0...40% or >40%	
Safety	Protection class IEC/EN	III Protective extra-low voltage (PELV)	
	Degree of protection IEC/EN	IP54 (for use of protective cap or grommet for RJ45 socket)	
EMC	EMC	CE according to 2014/30/EU	
	Mode of operation	Type 1	
	Rated impulse voltage supply / control	0.8 kV	
	Control pollution degree	3	
	Ambient temperature	-30...50 °C	
	Non-operating temperature	-40...80 °C	
	Ambient humidity	Max. 95% r.h., non-condensing	
	Materials	Measuring pipe	Brass body nickel-plated
		Closing element	Stainless steel
		Stem seal	O-ring EPDM
Immersion sleeve		Brass	
T-Piece		Brass body nickel-plated	

Safety notes



- This device has been designed for use in stationary heating, ventilation and air conditioning systems and must not be used outside the specified field of application, especially in aircraft or in any other airborne means of transport.
- Outdoor application: only possible in case that no (sea)water, snow, ice, insolation or aggressive gases interfere directly with the actuator and that is ensured that the ambient conditions remain at any time within the thresholds according to the data sheet.
- Only authorised specialists may carry out installation. All applicable legal or institutional installation regulations must be complied during installation.
- The connection between the control valve and the measuring tube should not be separated.
- The device contains electrical and electronic components and must not be disposed of as household refuse. All locally valid regulations and requirements must be observed.

Product features

Mode of operation The HVAC performance device is comprised of four components: characterised control valve (CCV), measuring pipe with volumetric flow sensor, temperature sensors and the actuator itself. The adjusted maximum flow (\dot{V}_{max}) is assigned to the maximum positioning signal (typically 10 V / 100%). Alternatively, the positioning signal can be assigned to the valve opening angle or to the power required on the heat exchanger (see power control). The HVAC performance device can be controlled communicative or analogue. The medium is detected by the sensor in the measuring pipe and is applied as the flow value. The measured value is balanced with the setpoint. The actuator corrects the deviation by changing the valve position. The angle of rotation α varies according to the differential pressure through the final controlling element (see flow rate curves).

Flow characteristic

Flow rate curves

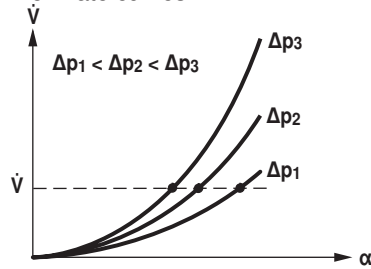
**Transmission behaviour HE**

Heat exchanger transmission behaviour
Depending on the construction, temperature spread, medium and hydraulic circuit, the power Q is not proportional to the water volumetric flow \dot{V} (Curve 1). With the classical type of temperature control, an attempt is made to maintain the control signal Y proportional to the power Q (Curve 2). This is achieved by means of an equal-percentage valve characteristic curve (Curve 3).

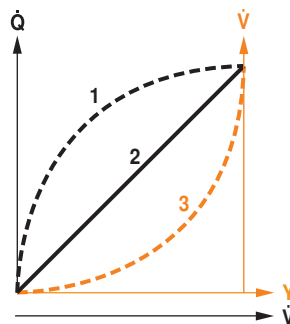
**Power control**

Alternatively, the positioning signal Y can be assigned to the output power required on the heat exchanger.
Depending on the water temperature and air conditions, the Energy Valve ensures the amount of water required \dot{V} to achieve the desired power.

Maximum controllable power on heat exchanger in power control mode:

DN 15	80 kW
DN 20	140 kW
DN 25	250 kW
DN 32	380 kW
DN 40	530 kW
DN 50	1010 kW

Control characteristics

The specially configured control parameters in connection with the precise velocity sensor ensure a stable quality of control. They are however not suitable for rapid control processes, i.e. for domestic water control.

Product features

Definition Flow control
 \dot{V}_{nom} is the maximum possible flow.

\dot{V}_{max} is the maximum flow rate which has been set with the greatest positioning signal. \dot{V}_{max} can be set between 30% and 100% of \dot{V}_{nom} .

\dot{V}_{min} 0% (non-variable).

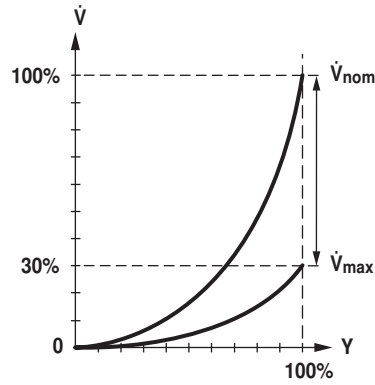

Definition Power control
 Q_{nom} is the maximum possible power output on the heat exchanger.

Q_{max} is the maximum power output on the heat exchanger which has been set with the greatest positioning signal. Q_{max} can be set between 1% and 100% of Q_{nom} .

Q_{min} 0% (non-variable).

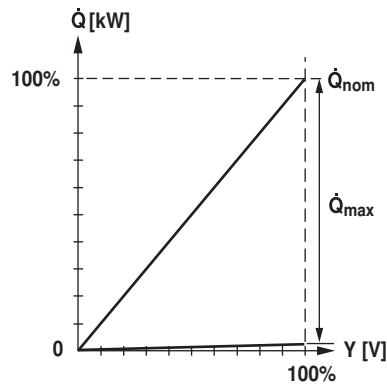

Product features

Creep flow suppression Given the very low flow speed in the opening point, this can no longer be measured by the sensor within the required tolerance. This range is overridden electronically.

Opening valve

The valve remains closed until the volumetric flow required by the positioning signal Y corresponds to 1% of \dot{V}_{nom} . The control along the valve characteristic curve is active after this value has been exceeded.

Closing valve

The control along the valve characteristic curve is active up to the required flow rate of 1% of \dot{V}_{nom} . Once the level falls below this value, the flow rate is maintained at 1% of \dot{V}_{nom} . If the level falls below the flow rate of 0.5% of \dot{V}_{nom} required by the reference variable Y, then the valve will close.

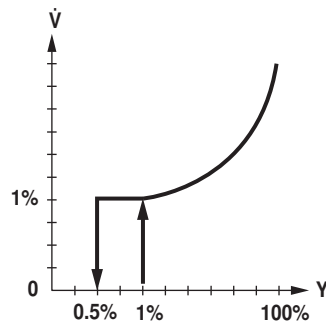

Communication The parameterisation can be carried out through the integrated web server (RJ45 connection to the web browser) or by communicative means. Additional information regarding the integrated web server can be found in the separate documentation.

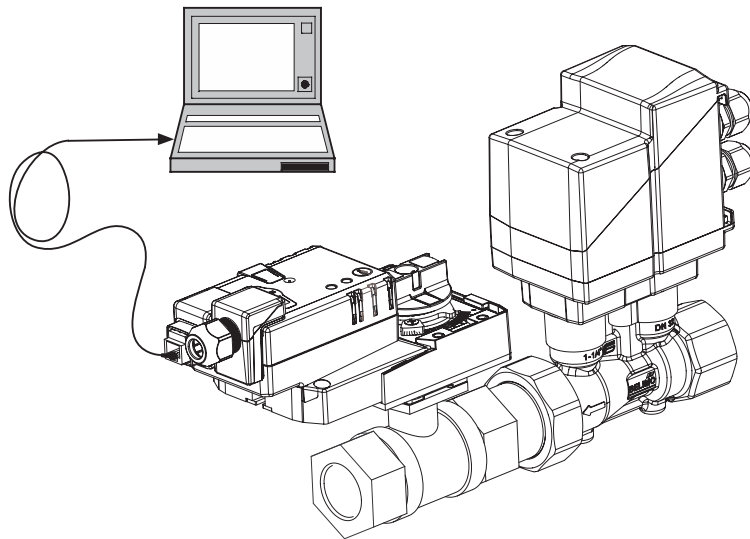

“Peer to Peer” connection

<http://belimo.local:8080>

The Notebook must be set to “DHCP”.
Make sure that only one network connection is active.

Standard IP address:

<http://192.168.0.10:8080>

Static IP address

Password (read-only):

User name: «guest»

Password: «guest»

Positioning signal inversion

This can be inverted in cases of control with an analogue positioning signal. The inversion causes the reversal of the standard behaviour, i.e. at a positioning signal of 0%, regulation is to \dot{V}_{max} or Q_{max} , and the valve is closed at a positioning signal of 100%.

Hydraulic balancing

Via the integrated web server, the maximum flow rate (equivalent to 100% requirement) can be adjusted on the device itself, simply and reliably, in a few steps. If the device is integrated in the management system, then the balancing can be handled directly by the management system.

Product features

Delta-T manager

If a heating or cooling register is operated with a differential temperature that is too low and thus with a flow rate that is too high, this will not result in an increased power output.

Nevertheless, heating or cooling machines must provide the energy at a lower degree of efficiency. This means, that pumps circulate too much water and increase energy consumption unnecessarily.

With the aid of the Energy Valve, it is simple to discover that operation is being carried out at a differential temperature that is too low, resulting in the inefficient use of energy. Necessary setting adjustments can now be carried out quickly and easily at any time. The integrated differential temperature limiting offers the user the possibility of defining a low limit value. The Energy Valve limits the flow rate automatically to prevent the level from falling below this value.

The settings of the Delta-T manager can be made either directly on the web server or via the Belimo Cloud a direct analysis of the Delta-T behavior is carried out by Belimo experts.

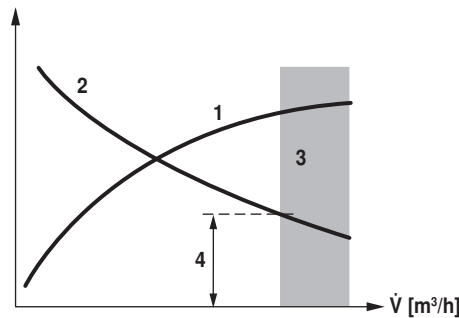

Power output of the heating or cooling registers 1
Diff. temperature between supply and return 2
Loss zone (heating or cooling register saturation) 3
Adjustable minimum differential temperature 4

Combination analogue - communicative (hybrid mode)

With conventional control by means of an analogue positioning signal, the integrated web server, BACnet, Modbus or MP-Bus can be used for the communicative position feedback.

Power and energy monitoring function

The final controlling device is equipped with two temperature sensors. A sensor (T2) must be installed at the valve and the second sensor (T1) must be installed on-site on the other side of the water circulation. The two sensors are enclosed with the system already wired. The sensors are used to record the medium temperature of the supply and return lines of the consumer (heating/cooling coil). As the water quantity is also known, thanks to the volumetric flow measurement integrated in the system, the power released from the consumer can be calculated. Furthermore, the heating/cooling energy is also determined automatically by means of the evaluation of the power over time.

The current data, e.g. temperatures, volumetric flow volumes, exchanger energy consumption etc. can be recorded and accessed at any time by means of web browsers or communication.

Data recording

The recorded data (integrated data recording for 13 months) can be used for the optimisation of the overall system and for the determination of the performance of the consumer.

Download csv files through web browser.

Belimo Cloud

Additional Services are available, if the Energy Valve is connected to the Belimo Cloud: For instance, several devices may be managed via Internet. Also Belimo experts may help analyze the Delta-T behavior or provide written reports about the Energy Valve performance. Under certain conditions, the product warranty according to the applicable Terms and Conditions of Sale may be prolonged. Further details may be found under [www.belimo.com/ext-warranty]

Glycolmonitoring

Glycolmonitoring measures the actual glycol content, which is necessary for safe operation and optimized heat exchange.

Manual override

Manual override with push-button possible (the gear is disengaged for as long as the button is pressed or remains locked).

High functional reliability

The actuator is overload protected, requires no limit switches and automatically stops when the end stop is reached.

Accessories

	Description	Type
Electrical accessories	Grommet to RJ connection module	Z-STRJ.1
	Connecting cable 5 m, A+B: RJ12 6/6, To ZTH EU	ZK1-GEN
Mechanical accessories	Pipe connector to ball valve DN 15 Rp 1/2"	ZR2315
	Insulation for EPIV / Energy Valve, DN15	EXT-OC-ZEP15
Service Tools		
	Service tool for parametrisable and communicative Belimo actuators / VAV controller and HVAC performance devices	ZTH EU

Electrical installation

Notes

- Connection via safety isolating transformer.
- Parallel connection of other actuators possible. Observe the performance data.
- The wiring of the line for BACnet MS/TP / Modbus RTU is to be carried out in accordance with applicable RS485 regulations.
- Modbus / BACnet: Supply and communication are not galvanically isolated. Connect earth signal of the devices with one another.

Wiring diagrams

Conventional operation

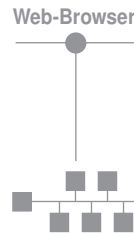
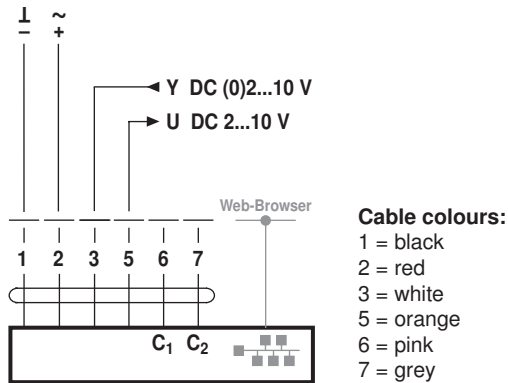

Connection of a notebook for parameterisation and manual control via RJ45.

Optional connection via RJ45 (direct connection Notebook / connection via Intranet or Internet) for access to the integrated web server

MP-Bus, supply via 3-wire connection

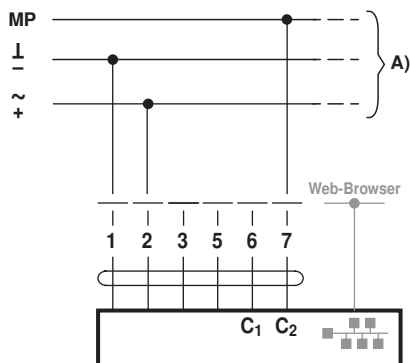

A) Additional actuators and sensors (max. 8)

Electrical installation

MP-Bus via 2-wire connection, local power supply

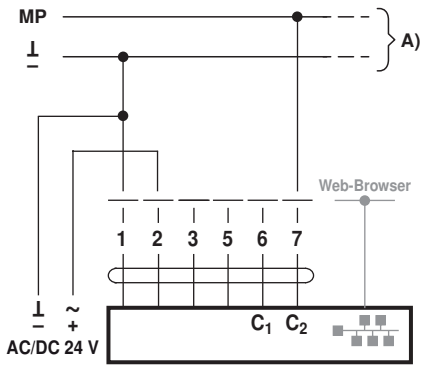

A) Additional actuators and sensors (max. 8)

Network topology

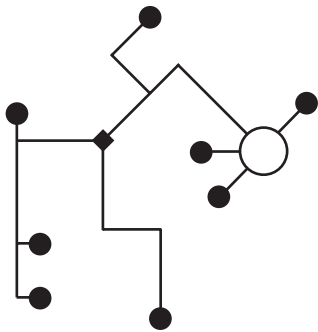

There are no restrictions for the network topology (star, ring, tree or mixed forms are permitted). Supply and communication in one and the same 3-wire cable

- no shielding or twisting necessary
- no terminating resistors required

Functions

Functions for actuators with specific parameters (Parametrisation with web server)

BACnet MS/TP / Modbus RTU

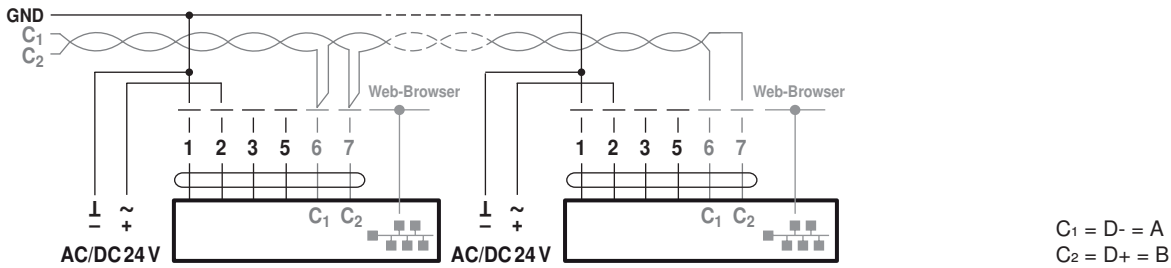

BACnet IP / Modbus TCP

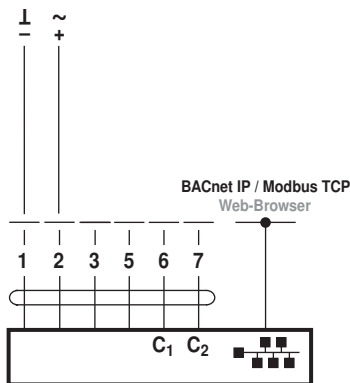

MP-Bus with analog setpoint (hybrid mode)

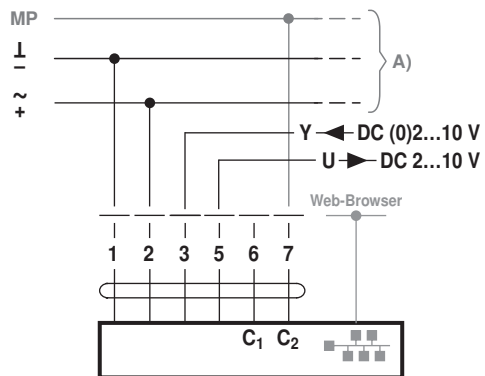

Functions

BACnet MS/TP / Modbus RTU with analog setpoint (hybrid mode) BACnet IP / Modbus TCP with analog setpoint (hybrid mode)

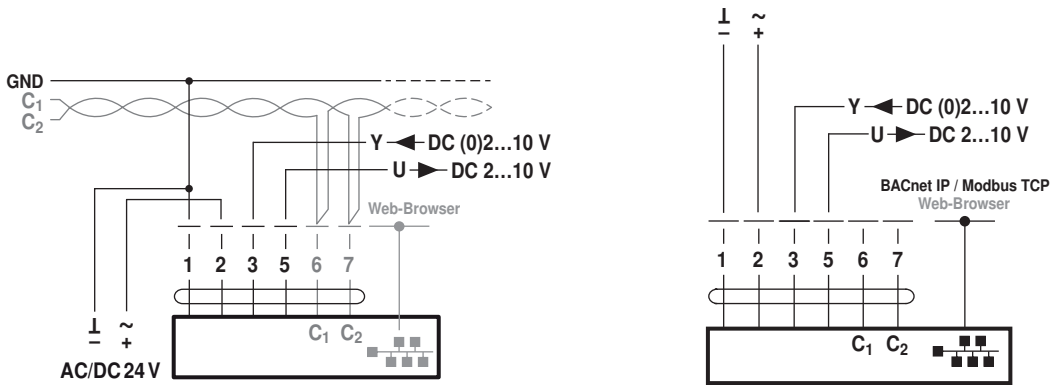

Override control and limiting with DC 24 V with relay contacts (with conventional control or hybrid mode)

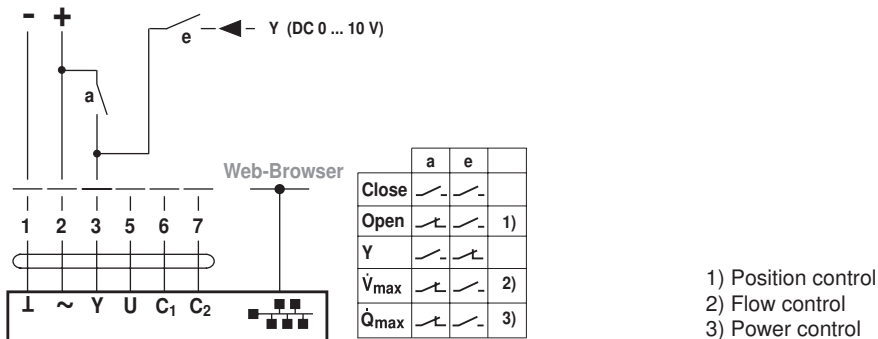

Operating controls and indicators

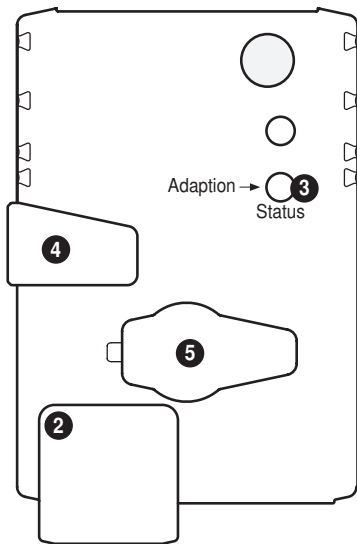

- 2 LED display green**
Off: No power supply or wiring errors
On: In operation
Flickering: Internal communication (Valve/Sensor)
- 3 Push-button and LED display yellow**
On: Adaptation process active
Press button: Triggers angle of rotation adaptation, followed by standard mode
- 4 Gear disengagement button**
Press button: Gear disengages, motor stops, manual override possible
Release button: Gear engages, synchronisation starts, followed by standard mode
- 5 Service plug**
For connecting the ZTH EU

Installation notes

Recommended installation positions The ball valve can be installed upright to horizontal. The ball valve may not be installed in a hanging position, i.e. with the stem pointing downwards.

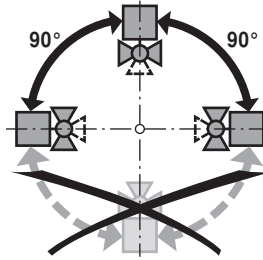

Mounting position in the return Installation in the return is recommended.

Water quality requirements The water quality requirements specified in VDI 2035 must be adhered to. Belimo valves are regulating devices. For the valves to function correctly in the long term, they must be kept free from particle debris (e.g. welding beads during installation work). The installation of suitable strainer is recommended.

Maintenance Ball valves, rotary actuators and sensors are maintenance-free.

Before any service work on the final controlling device is carried out, it is essential to isolate the rotary actuator from the power supply (by unplugging the electrical cable if necessary). Any pumps in the part of the piping system concerned must also be switched off and the appropriate slide valves closed (allow all components to cool down first if necessary and always reduce the system pressure to ambient pressure level).

The system must not be returned to service until the ball valve and the rotary actuator have been correctly reassembled in accordance with the instructions and the pipeline has been refilled by professionally trained personnel.

Flow direction The direction of flow, specified by an arrow on the housing, is to be complied with, since otherwise the flow rate will be measured incorrectly.

Inlet section In order to achieve the specified measuring accuracy, a flow-calming section or inflow section in the direction of the flow is to be provided upstream from the flow sensor. Its dimensions should be at least 5x DN.

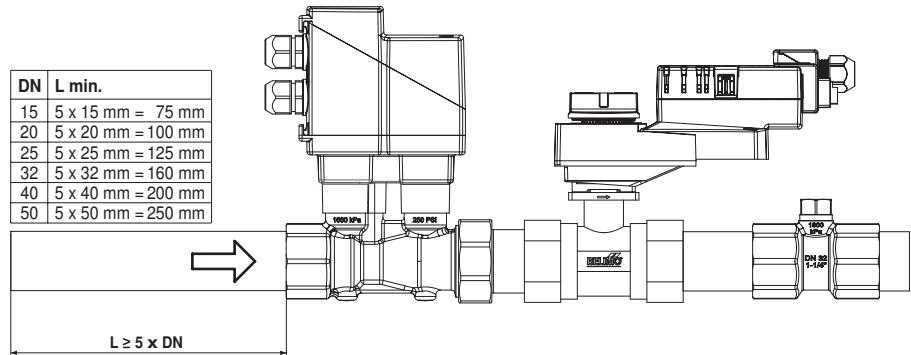

Installation notes

Installation of immersion sleeve and temperature sensor

The valve is equipped with two fully-wired temperature sensors.

- T2: This sensor is installed on site near the valve unit.
- T1: This sensor is installed on site ahead of the consumer (valve in the return line) or after the consumer (valve in the supply line).

Two T-pieces for installation of the temperature sensors in the pipelines are included in the shipment.

Note

The cables between valve unit and temperature sensors may not be either shortened or lengthened.

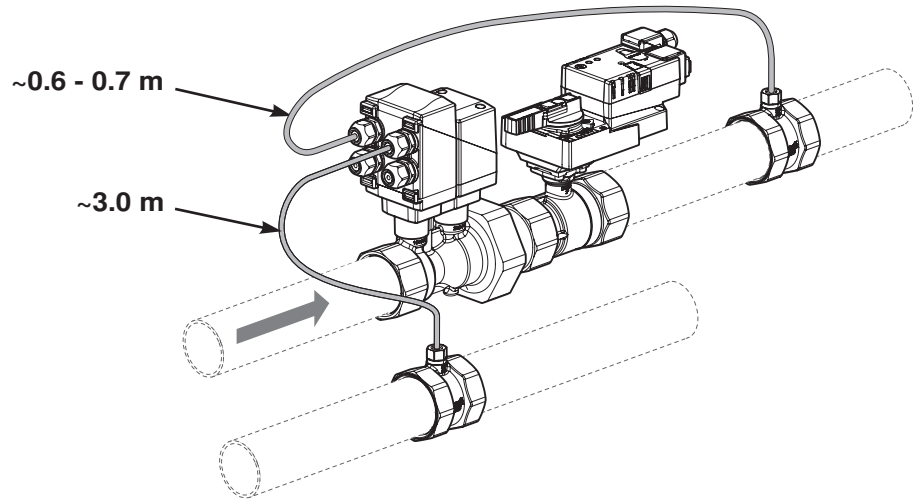

General notes

Valve selection The valve is determined using the maximum required flow rate \dot{V}_{\max} .

A calculation of the kvs value is not required.

$\dot{V}_{\max} = 30 \dots 100\%$ of \dot{V}_{nom}

If no hydraulic data are available, then the same valve DN can be selected as the heat exchanger nominal diameter.

Minimum differential pressure (pressure drop)

The minimum required differential pressure (pressure drop through the valve) for achieving the desired volumetric flow \dot{V}_{\max} can be calculated with the aid of the theoretical kvs value (see type overview) and the below-mentioned formula. The calculated value is dependent on the required maximum volumetric flow \dot{V}_{\max} . Higher differential pressures are compensated for automatically by the valve.

Formula

$$\Delta p_{\min} = 100 \times \left(\frac{\dot{V}_{\max}}{k_{vs \text{ theor.}}} \right)^2$$

Δp_{\min} : kPa
\dot{V}_{\max} : m ³ /h
$k_{vs \text{ theor.}}$: m ³ /h

Example (DN25 with the desired maximum flow rate = 50% \dot{V}_{nom})

EV025R+BAC

kvs theor. = 8.6 m³/h

$\dot{V}_{\text{nom}} = 69$ l/min

50% * 69 l/min = 34.5 l/min = 2.07 m³/h

$$\Delta p_{\min} = 100 \times \left(\frac{\dot{V}_{\max}}{k_{vs \text{ theor.}}} \right)^2 = 100 \times \left(\frac{2.07 \text{ m}^3/\text{h}}{8.6 \text{ m}^3/\text{h}} \right)^2 = 6 \text{ kPa}$$

Valve selection

In case of a flow sensor error, the Energy Valve will switch from either Power or Flow control to Position control (Delta-T manager will be deactivated).

Once the error disappears, the Energy Valve will switch back to the normal control setting (Delta-T manager activated)

Dimensions / Weight

Dimensional drawings

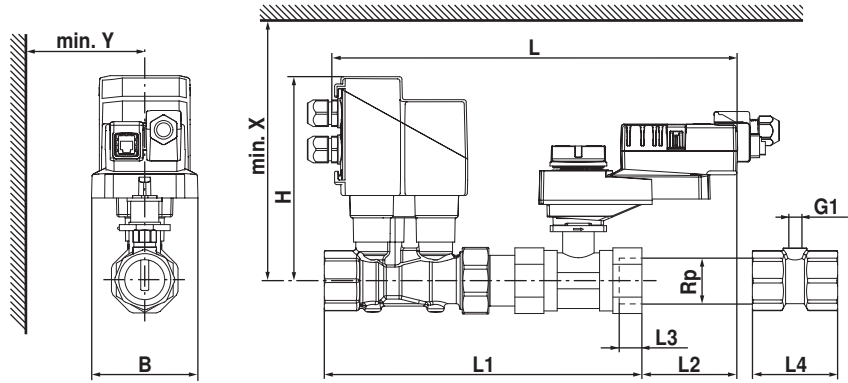

Type	DN []	Rp ["]	L [mm]	L1 [mm]	L2 [mm]	L3 [mm]	B [mm]	H [mm]	G1	L4 [mm]	X [mm]	Y [mm]	Weight [kg]
EV015R+BAC1	15	1/2	275	192	81	13	75	160	G1/4"	53	230	77	1.6
EV020R+BAC1	20	3/4	291	211	75	14	75	162	G1/4"	57	232	77	1.9
EV025R+BAC1	25	1	295	230	71	16	75	165	G1/4"	65	235	77	2.1
EV032R+BAC1	32	1 1/4	323	255	68	19	85	168	G1/4"	71	238	77	2.9
EV040R+BAC1	40	1 1/2	325	267	65	19	85	172	G1/4"	71	242	77	3.4
EV050R+BAC1	50	2	343	288	69	22	95	177	G1/4"	80	247	77	5.0

Further documentation

- Overview MP Cooperation Partners
- Tool connections
- General notes for project planning
- Instruction Webserver
- Description Data-Pool Values
- Description Protocol Implementation Conformance Statement PICS
- Description Modbus register
- Introduction to MP-Bus Technology