



Oil Burner Controls

LMO64...

Microcontroller-based oil burner controls for the startup, supervision and control of forced draft oil burners in intermittent operation. Maximum oil throughput up to 30 kg/h.

The LMO64... and this Data Sheet are intended for use by OEMs which integrate the burner controls in their products.

Use, features

Use	The LMO64... burner controls are designed for the startup and supervision of 1-stage forced draft oil burners in intermittent operation. Yellow-burning flames are supervised with photo resistive detectors QRB..., blue-burning flames with blue-flame detectors QRC...
General features	<ul style="list-style-type: none"> - Oil burners with fan conforming to EN 267 - Burner controls for use with atomization oil burners of monoblock design conforming to DIN EN 230:2005-10 - Undervoltage detection - Electrical remote reset - Bridging contact for oil preheater - Monitoring of time for oil preheater - Accurate and reproducible program sequence through digital signal handling - Controlled intermittent operation after 24 hours of continuous operation - Limitation of the number of repetitions - Multicolor indication of fault and status messages
Specific features	<ul style="list-style-type: none"> - Postpurge function for clearing the combustion chamber after burner operation

Warning notes



To avoid injury to persons, damage to property or the environment, the following warning notes must be observed!

Do not open, interfere with or modify the unit!

- All activities (mounting, installation and service work, etc.) must be performed by qualified staff
- Before making any wiring changes in the connection area, completely isolate the plant from mains supply (all-polar disconnection). Ensure that the plant cannot be inadvertently switched on again and that it is indeed dead. If not observed, there is a risk of electric shock hazard
- Ensure protection against electric shock hazard by providing adequate protection for the burner control's connection terminals
- Each time work has been carried out (mounting, installation, service work, etc.), check to ensure that wiring is in an orderly state and make the safety checks as described in «Commissioning notes»
- Press the lockout reset button / operation button only manually (applying a force of no more than 10 N), without using any tools or pointed objects
- Fall or shock can adversely affect the safety functions. Such units must not be put into operation, even if they do not exhibit any damage

Mounting notes

- Ensure that the relevant national safety regulations are complied with

Installation notes

- Always run the high-voltage ignition cables separately while observing the greatest possible distances to the unit and to other cables
- Install switches, fuses, earthing, etc., in compliance with local regulations
- Ensure that the maximum permissible amperages will not be exceeded (refer to «Technical data»)
- Do not feed external mains voltage to the control outputs of the unit. When testing the devices controlled by the burner control (fuel valves, etc.), the LMO64... must never be plugged in
- Do not mix up live and neutral conductors
- To ensure that the LMO64... does not get mixed up with other types of burner controls, it may only be used in connection with the grey AGK11.6 plug-in base. In particular, it must be made certain that the line for the control thermostat or pressur-estat «R» is picked up after the limit thermostat and pressure switch «W» and safety limit thermostat «SB», to be connected to terminal 7 (refer to «Connection diagram»)



Electrical connection of the flame detector

It is important to achieve practically disturbance- and loss-free signal transmission:

- Never run the detector cable together with other cables
 - Line capacitance reduces the magnitude of the flame signal
 - Use a separate cable
- Note the maximum permissible detector cable lengths (refer to «Technical data»)

Commissioning notes

- When commissioning the plant or when doing maintenance work, make the following safety checks:

	Safety check	Anticipated response
a)	Burner startup with flame detector darkened	Lockout at the end of «TSA»
b)	Burner startup with flame detector exposed to extraneous light	Lockout after no more than 40 seconds
c)	Burner operation with simulated flame failure; for that purpose, darken the flame detector during operation and maintain that status	Start repetition followed by lockout at the end of «TSA»

Standards and certificates



Conformity to EEC directives
 - Electromagnetic compatibility EMC (immunity)
 - Low-voltage directive

2004/108/EC
 2006/95/EC



ISO 9001: 2000
 Cert. 00739



ISO 14001: 2004
 Cert. 38233



Identification code to EN 230:

F M L L X N

Life cycle

Burner controls has a designed lifetime* of 250,000 burner startup cycles which, under normal operating conditions in heating mode, correspond to approx. 10 years of usage (starting from the production date given on the type field). This lifetime is based on the endurance tests specified in standard EN230 and the table containing the relevant test documentation as published by the European Association of Component Manufacturers (Afecor) (www.afecor.org).

The designed lifetime is based on use of the burner controls according to the manufacturer's Data Sheet. After reaching the designed lifetime in terms of the number of burner startup cycles, or the respective time of usage, the burner control is to be replaced by authorized personnel.

* The designed lifetime is not the warranty time specified in the Terms of Delivery

Disposal notes



The unit contains electrical and electronic components and must not be disposed of together with domestic waste.
 Local and currently valid legislation must be observed.

Mechanical design

The housing is made of impact-proof, heat-resistant and flame-retarding plastic. It is of plug-in design and engages audibly in the base. Burner controls type LMO64... and AGK11.6 plug-in bases are silver-grey (RAL7001).

The housing accommodates the

- microcontroller, which controls the program sequence, and the print relays for load control,
- electronic flame signal amplifier,
- lockout reset button with its integrated multicolor signal lamp for status and fault messages and the socket for connecting the OCI400 interface adapter

Display and diagnostics

- Multicolor display of status and fault messages
- Transmission of status and fault messages as well as detailed service information by additional OCI400 interface adapter and PC Windows software ACS400 / ACS410

Type summary

Type reference	Mains voltage	Fuel valve stages	Burner capacity	1)	Remote reset	Times						
						tw max.	t1 / t1' min.	TSA max.	t3 min.	t3n max.	t4 min.	t8 max.
Standard versions												
LMO64.300C2	AC 230 V	1	<30 kg/h	•	•	2.5 s	15 / 16 s	10 s	15 s	10 s	---	20 s
LMO64.301C2	AC 230 V	1	<30 kg/h	•	•	2.5 s	15 / 16 s	10 s	15 s	10 s	---	90 s
LMO64.302C2 *	AC 230 V	1	<30 kg/h	•	•	2.5 s	15 / 16 s	10 s	15 s	3 s	---	20 s

* On request only!

Legend

TSA	Ignition safety time
tw	Waiting time
t1	Prepurge time
t1'	Purge time
t3	Preignition time
t3n	Postignition time
t4	Interval from flame signal to the release of «BV2»
t8	Postpurge time
1)	Bridging contact for oil preheater

Oil burner control , (without plug-in base, grey version)	refer to «Type summary»
Connection accessories for small burner controls	refer to Data Sheet N7201
- Plug-in base AGK11.6 (grey version)	
- Cable holders AGK65, AGK66, AGK67...	
- Cable strain relief elements for AGK67...	
Flame detectors	
- Photo resistive detectors QRB1...	refer to Data Sheet N7714
- Blue-flame detectors QRC1...	refer to Data Sheet N7716
Interface OCI400...	refer to Data Sheet N7614
Interface between burner control and PC Facilitates viewing and recording setting parameters on site in connection with the ACS400 / ACS410 software	
PC software ACS400	refer to User Documentation J7350
PC software for visualizing the burner controls	
PC software ACS410	refer to User Documentation J7352
PC software for setting the parameters and for visualizing the burner controls	

Technical data

General unit data	Mains voltage	AC 230 V +10 % / -15 %
	Mains frequency	50...60 Hz \pm 6 %
	External primary fuse (Si)	6.3 A (slow)
	Power consumption	12 VA
	Perm. mounting position	Optional
	Weight	Approx. 200 g
	Safety class	I (burner control with plug-in base)
	Degree of protection	IP40 (to be ensured through mounting)
	Perm. cable lengths	Max. 3 m at a line capacitance of 100 pF/m
	- from terminal 7 to «R»	Max. 20 m at 100 pF/m
	Detector cable laid separately	10 m
	Remote reset laid separately	20 m

Perm. amperage at $\cos \varphi \geq 0.6$	LMO64...
Terminal 1	Max. 5 A
Terminals 3 and 8	Max. 3 A
Terminals 4, 5, 6 and 10	Max. 1 A

Environmental conditions

Storage	DIN EN 60721-3-1
Climatic conditions	Class 1K3
Mechanical conditions	Class 1M2
Temperature range	-20...+60 °C
Humidity	<95 % r.h.
Transport	DIN EN 60721-3-2
Climatic conditions	Class 2K2
Mechanical conditions	Class 2M2
Temperature range	-20...+60 °C
Humidity	<95 % r.h.
Operation	DIN EN 60721-3-3
Climatic conditions	Class 3K3
Mechanical conditions	Class 3M3
Temperature range	-5...+60 °C
Humidity	<95 % r.h.



Condensation, formation of ice and ingress of water are not permitted!

Technical data (cont'd)

Flame supervision with QRB... and QRC...

	Required detector current (with flame)	Perm. detector current (without flame)	Possible detector current with flame (typically)
QRB...¹⁾	Min. 45 µA	Max. 5.5 µA	Max. 100 µA
QRC...¹⁾	Min. 70 µA	Max. 5.5 µA	Max. 100 µA

Green LED for operational status indication

	Detector current in operation: - Flame signal instable - Green LED flashing	Detector current in operation: - Flame signal stable - Green LED steady on
QRB...¹⁾	<45 µA	>45 µA
QRC...¹⁾	<45 µA	>45 µA

- 1) The values given in the table above only apply under the following conditions:
- Mains voltage depending on execution AC 230 V
 - Ambient temperature 23 °C

Measurement circuit for detector current

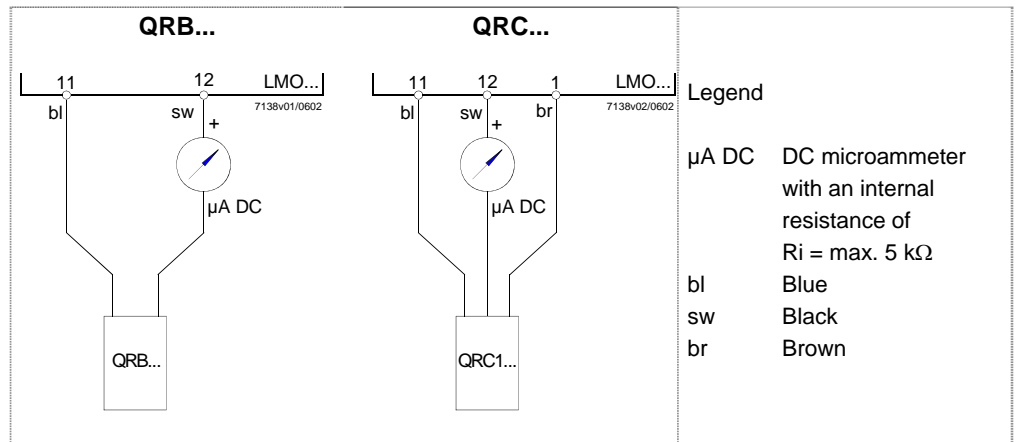

As an alternative to detector current measurement, the diagnostic tool OCI400 / ACS400 / ACS410 can be used. In that case, connection of the DC microammeter is not required.

Function

Preconditions for startup	<ul style="list-style-type: none"> • Burner control is reset • Reset button «EK1» or «EK2» not used • All contacts in the line are closed and there is demand for heat • No undervoltage • Flame detector is darkened and there is no extraneous light
Undervoltage	<ul style="list-style-type: none"> • Safety shutdown from the operating position takes place should mains voltage drop below about AC 165 V (U_N = AC 230 V) • Restart is initiated when mains voltage exceeds about AC 175 V (U_N = AC 230 V)
Time supervision oil preheater	If the oil preheater's release contact does not close within 10 minutes, the burner control will initiate lockout.
Controlled intermittent operation	After 24 hours of continuous operation at the latest, the burner control will initiate automatic safety shutdown followed by a restart.
Control sequence in the event of fault	If lockout occurs, the outputs for the fuel valves, burner motor and ignition equipment will immediately be deactivated (<1 second). In the event of lockout, the LMO64... remains locked, and the red signal lamp will light up. The burner control can immediately be reset. This status is also maintained in the case of a mains failure.

Cause	Response
Mains failure	Restart
Voltage has fallen below the undervoltage threshold	Safety shutdown, followed by restart
Extraneous light during «t1», 5 s before «BV1» release	Lockout at the end of «t1»
Extraneous light during «tw»	Prevention of startup, lockout after no more than 40 seconds
No flame at the end of «TSA»	Lockout at the end of «TSA», blink code 2
Flame is lost during operation	Max. 3 repetitions, followed by lockout
Oil preheater's release contact does not close within 10 min.	Lockout

Resetting the burner control	Whenever lockout occurs, the burner control can immediately be reset. To do this, press the lockout reset button for about 1 second (<3 seconds). The LMO... can only be reset when all contacts in the line are closed and when there is no undervoltage.
Ignition program with LMO64.302...	If the flame is lost during «TSA», the burner will be reignited, but not later than at the end of «TSA». This means that several ignition attempts can be made during «TSA» (refer to «Program sequence»).
Limitation of repetitions	If the flame is lost during operation, a maximum of 3 repetitions can be made. Each time the flame is lost during operation, safety lockout will be initiated. The repetition count is restarted each time controlled switching on by «R» takes place.
Postpurging	Postpurging is only possible when the oil preheater contact is closed or when the wire link between terminals 3 and 8 is fitted. A demand for heat via «R» during postpurge time «t8», implicates an interruption of postpurging, followed by new start.

Operation, display, diagnostics

Operation

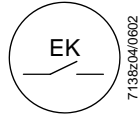

7138z04/0602

Lockout reset button «EK» is the key operating element for resetting the burner control and for activating / deactivating the diagnostic functions.

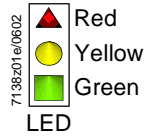

The multicolor LED is the key indicating element for both visual diagnostics and interface diagnostics.

Both «EK» and LED are located under the transparent cover of the lockout reset button.

There are 2 diagnostic choices available:

1. Visual diagnostics: Operating state indication or diagnostics of the cause of fault
2. Interface diagnostics: With the help of the OCI400 interface adapter and PC software ACS400 / ACS410 or flue gas analyzers of different makes.

Visual diagnostics:

In normal operation, the different operating states are indicated in the form of color codes according to the color code table.

Operating state indication

During startup, indication of the operating state takes place according to the following table:

Color code table for multicolor «LED» signal lamp		
State	Color code	Color
Waiting time «tw», standby on continuous phase, waiting status	○.....	Off
Oil preheater heats	●.....	Yellow
Ignition phase, ignition controlled	● ○ ● ○ ● ○ ● ○ ● ○ ●	Flashing yellow
Operation, flame o.k.	□.....	Green
Operation, flame not o.k.	□ ○ □ ○ □ ○ □ ○ □ ○	Flashing green
Extraneous light on burner startup	□ ▲ □ ▲ □ ▲ □ ▲ □ ▲ □	Green-red
Undervoltage	● ▲ ● ▲ ● ▲ ● ▲ ● ▲ ●	Yellow-red
Fault, alarm	▲.....	Red
Output of fault code (refer to «Error code table»)	▲○ ▲○ ▲○ ▲○ ▲○ ▲○	Flashing red
Interface diagnostics	▲ ▲ ▲ ▲ ▲ ▲ ▲	Red flicker light

Legend

.....	Steady on	▲	Red
○	Off	●	Yellow
		□	Green

Operation, display, diagnostics (cont'd)

Diagnostics of cause of fault

After lockout, the red fault signal lamp remains steady on. In that condition, the visual diagnostics of the cause of fault according to the error code table can be activated by pressing the lockout reset button for more than 3 seconds. Pressing the reset button again for at least 3 seconds, the interface diagnostics will be activated. If, by accident, interface diagnostics has been activated, in which case the slightly red light of the signal lamp flickers, it can be deactivated by pressing again the lockout reset button for at least 3 seconds. The moment of switching over is indicated by a yellow light pulse.

The following sequence activates the diagnostics of the cause of fault:

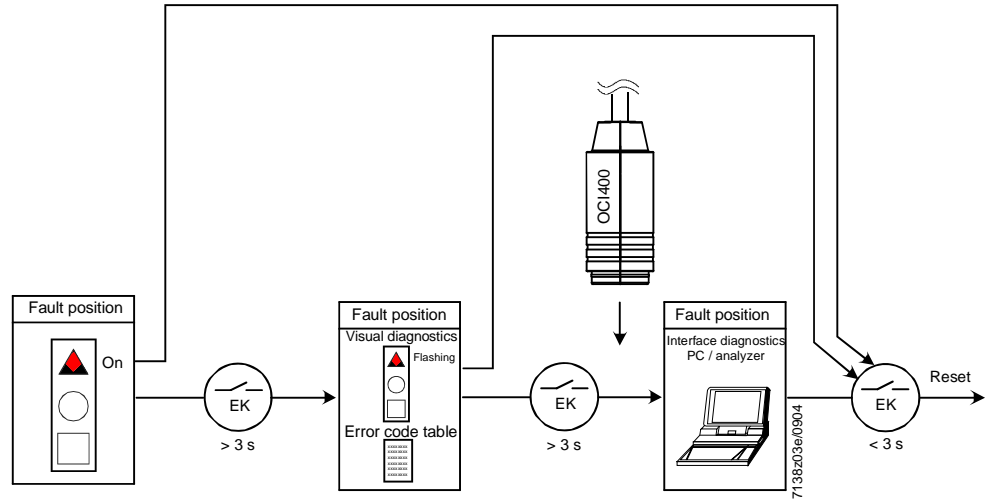

Error code table		
Blink code «red» of «LED» signal lamp	«AL» at terminal 10	Possible cause
2 blinks	On	No establishment of flame at the end of «TSA» - Faulty or soiled fuel valves - Faulty or soiled flame detector - Poor adjustment of burner, no fuel - Faulty ignition equipment
3 blinks	On	Free
4 blinks	On	Extraneous light on burner startup
5 blinks	On	Free
6 blinks	On	Free
7 blinks	On	Too many losses of flame during operation (limitation of the number of repetitions) - Faulty or soiled fuel valves - Faulty or soiled flame detector - Poor adjustment of burner
8 blinks	On	Timer supervision oil preheater
9 blinks	On	Free
10 blinks	Off	Wiring fault or internal fault, output contacts, other faults

During the time the cause of fault is diagnosed, the control outputs are deactivated. The burner remains shut down. The diagnostics of the cause of fault is quit and the burner switched on again by resetting the burner control. Press lockout reset button for about 1 second (<3 seconds).

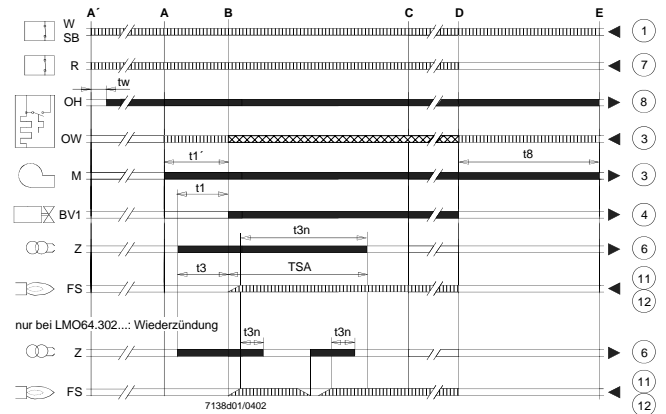
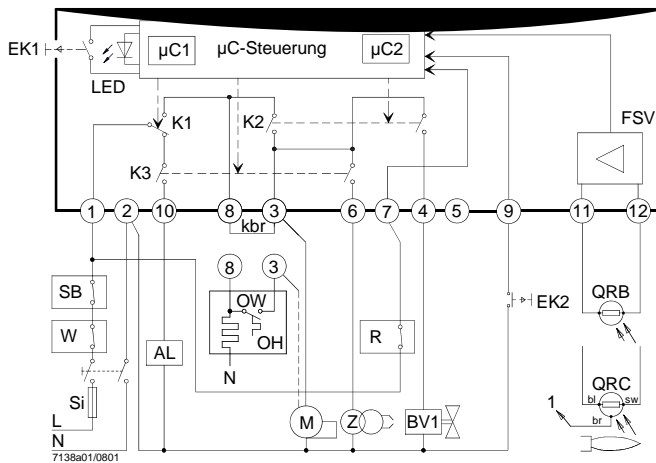

Legend

AL	Alarm device	OW	Release contact of oil preheater
BV...	Fuel valve	OH	Oil preheater
EK1	Lockout reset button	QRB	Photo resistive detector
EK2	Remote lockout reset button	QRC	Blue-flame detector
FS	Flame signal		bl = blue, br = brown, sw = black
FSV	Flame signal amplifier	R	Control thermostat or pressurestat
K...	Contacts of control relay	SB	Safety limit thermostat
kbr	Cable link (required only when oil preheater is not used)	Si	External primary fuse
LED	3-color signal lamps	W	Limit thermostat or pressure switch
M	Burner motor	Z	Ignition transformer
TSA	Ignition safety time	t3n	Postignition time
tw	Waiting time	t4	Interval between flame signal and release «BV2»
t1	Prepurge time	t8	Postpurge time
t1'	Purge time		
t3	Preignition time		
A'	Beginning of startup sequence with burners using «OH»	C	Operating position
A	Beginning of startup sequence with burners using no «OH»	D	Controlled shutdown by «R»
B	Time of flame establishment	E	End of startup sequence
█	Control signals	µC1	Microcontroller 1
▤	Required input signals	µC2	Microcontroller 2
▨	Permissible input signals		

Dimensions

Dimensions in mm

LMO64...



Plug-in base AGK11... /
AGK13...

