

Pressure-independent characterised control valves, 2-way, with internal thread

- For closed cold and warm water systems
- For modulating water-side control of air purification and heating systems

Type overview

Type	DN	Vnom [l/s]	Vmax	Rp ["]	ps [kPa]	Sv min. []
R215P-010	15	0.1	0.04...0.1 l/s	1/2	1600	50
R215P-040	15	0.4	0.10...0.4 l/s	1/2	1600	50
R220P-040	20	0.4	45...100% of Vnom	3/4	1600	100
R220P-060	20	0.6	45...100% of Vnom	3/4	1600	100
R225P-070	25	0.7	45...100% of Vnom	1	1600	100
R225P-110	25	1.1	45...100% of Vnom	1	1600	100
R232P-120	32	1.2	45...100% of Vnom	1 1/4	1600	100
R232P-160	32	1.6	45...100% of Vnom	1 1/4	1600	100
R240P-180	40	1.8	45...100% of Vnom	1 1/2	1600	100
R240P-220	40	2.2	45...100% of Vnom	1 1/2	1600	100
R250P-270	50	2.7	45...100% of Vnom	2	1600	100
R250P-550	50	5.5	45...100% of Vnom	2	1600	100

Technical data

Functional data	Media	Cold and hot water, water with glycol up to max. 50% vol.	
	Medium temperature	DN 15...DN 20: 5°C...100°C DN 25...DN 50: 5°C...80°C	
	Medium temperature note	lower temperatures on request	
	Pressure value	30 kPa ... 350 kPa	
	Closing pressure Δps	700 kPa	
	Flow characteristic	Equal percentage (in accordance with VDI/VDE	
	Pressure stability	With a pressure value of 35 ... 350 kPa: $\pm 10\%$, in the lower pressure value range: $\pm 15\%$	
	Leakage rate	Class IV with 350 kPa (IEC 60534-4)	
	Pipe connections	Internal thread in accordance with ISO 7/1	
	Angle of rotation	90°, (operating range 15 ... 90°)	
	Installation position	Upright to horizontal (in relation to the stem)	
	Maintenance	Maintenance-free	
	Materials	Valve	DN 15...DN 25: Forged brass, body nickel-plated DN 32...DN 50: Cast, nickel-plated brass body
		Valve cone	Chrome-plated brass
Stem		Chrome-plated brass	
Stem seal		O-ring EPDM	
Valve seat		PTFE, O-ring Viton	
Characterising disk		DN 15...DN 20: Brass DN 25...DN 50: TEFZEL	
Cage		Brass	
Diaphragm		Polyester-reinforced silicone	
Spring to valve cone		stainless steel	
Terms		Abbreviations	Vnom = nominal flow with valve completely opened Vmax = maximum flow set by the angle of rotation limitation on the actuator

Safety notes



- The ball valve has been designed for use in stationary heating, ventilation and air conditioning systems and is not allowed to be used outside the specified field of application, especially in aircraft or in any other airborne means of transport.
- Only authorised specialists may carry out installation. All applicable legal or institutional installation regulations must be complied with during installation.
- The ball valve does not contain any parts that can be replaced or repaired by the user.
- The ball valve may not be disposed of as household refuse. All locally valid regulations and requirements must be observed.
- When determining the flow rate characteristic of controlled devices, the recognised directives must be observed.

Product features

Principle of operation	The ball valve is adjusted by a rotary actuator. The rotary actuator is controlled by a commercially available modulating or 3-point control system and moves the ball of the valve – the throttling device – to the position dictated by the positioning signal. Open the characterised control valve counterclockwise and close it clockwise.
Flow characteristic	Equal percentage flow control is ensured by the integrated characterising disk.
Constant flow volume	With a pressure value of 30 ... 350 kPa, a constant flow volume is achieved thanks to the integrated pressure-reducing valve. Independent of the differential pressure through the valve, a valve authority of 1 is achieved. Even in the part-load range, the flow rate remains constant with each respective opening position (angle of rotation) and ensures a steady control.

Accessories

	Description	Type
Mechanical accessories	Pipe connector, to characterised control valve DN 15	ZR2315
	Pipe connector, to characterised control valve DN 20	ZR2320
	Pipe connector, to characterised control valve DN 25	ZR2325
	Pipe connector, to characterised control valve DN 32	ZR2332
	Pipe connector, to characterised control valve DN 40	ZR2340
	Pipe connector, to characterised control valve DN 50	ZR2350

Installation notes

Recommended installation positions The ball valve can be installed upright to horizontal. The ball valve may not be installed in a hanging position, i.e. with the stem pointing downwards.

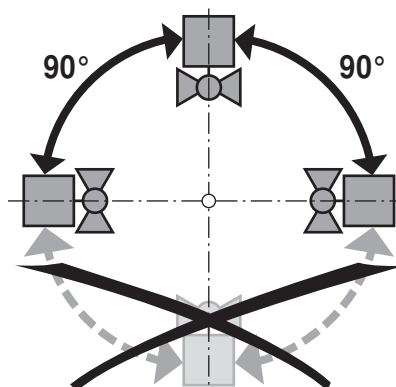

Installation position in return Installation in the return is recommended.

Water quality requirements The water quality requirements specified in VDI 2035 must be adhered to. Ball valves are regulating devices. The use of dirt filters is recommended in order to prolong their service life as modulating instruments.

Installation notes

- Maintenance** Ball valves and rotary actuators are maintenance-free.
Before any kind of service work is carried out on the actuator, it is essential to isolate the rotary actuator from the power supply (by unplugging the electrical cable). Any pumps in the part of the piping system concerned must also be switched off and the appropriate slide valves closed (allow everything to cool down first if necessary and reduce the system pressure to ambient pressure level).
The system must not be returned to service until the ball valve and the rotary actuator have been properly reassembled in accordance with the instructions and the pipeline has been refilled in the proper manner.
- Flow direction** The direction of flow, specified by an arrow on the housing, is to be complied with, since otherwise the ball valve could become damaged. Please ensure that the ball is in the correct position (marking on the stem).

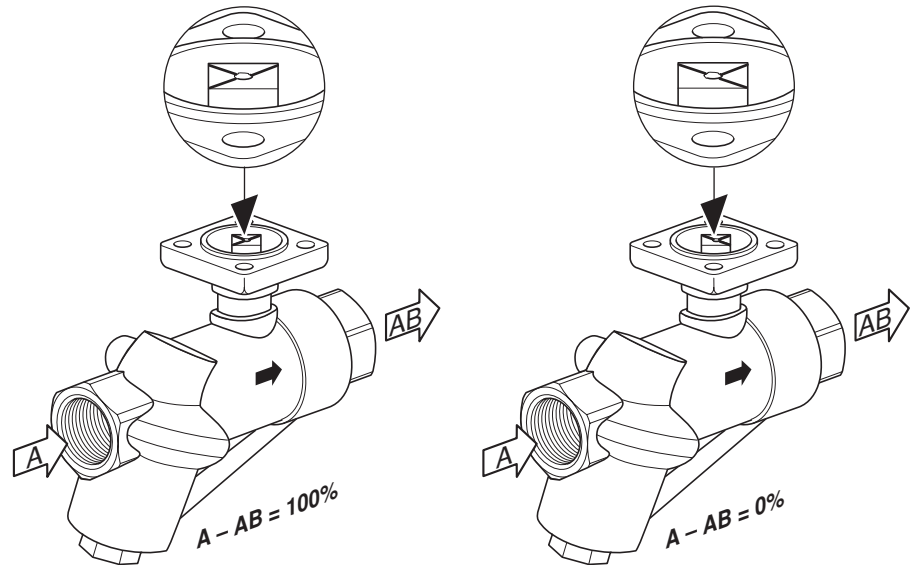

Dimensions [mm] / weight

Dimensional drawings

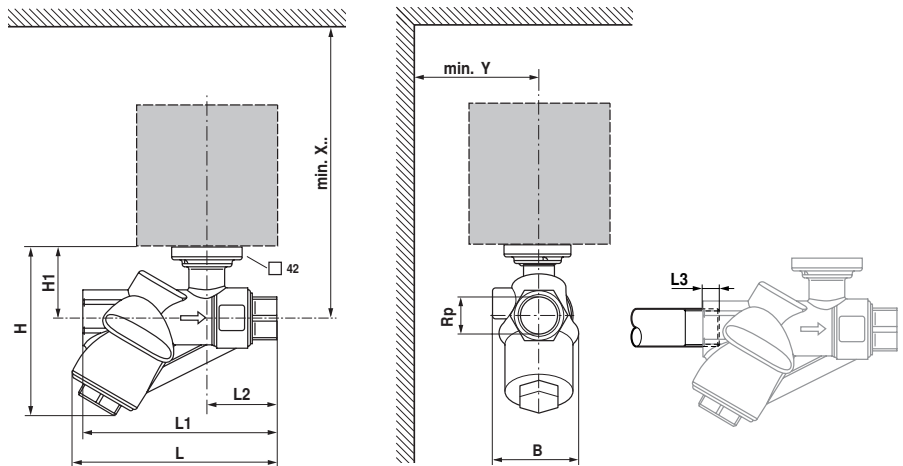

L3: Maximum screwing depth

Y/X2: Minimum distance with respect to the valve centre LR..A

Y/X3: Minimum distance with respect to the valve centre NR..

The actuator dimensions can be found on the respective actuator data sheet.

Type	DN	Rp ["]	L [mm]	L1 [mm]	L2 [mm]	L3 [mm]	B [mm]	H [mm]	H1 [mm]	Y [mm]	X2 [mm]	X3 [mm]	Weight [kg]
R215P-010	15	1/2	119	114	38	13	51	94	36	70	200	250	0.9
R215P-040	15	1/2	119	114	38	13	51	94	36	70	200	250	0.9
R220P-040	20	3/4	126	126	43	14	51	94	36	70	200	250	0.9
R220P-060	20	3/4	126	126	43	14	51	94	36	70	200	250	0.9
R225P-070	25	1	179	179	63	16	82	121	46	70	200	250	2.8
R225P-110	25	1	179	179	63	16	82	121	46	70	200	250	2.8
R232P-120	32	1 1/4	221	221	62	19	87	140	51	70	200	250	3.8
R232P-160	32	1 1/4	221	221	62	19	87	140	51	70	200	250	3.8
R240P-180	40	1 1/2	204	204	65	19	87	140	51	70	200	250	3.6
R240P-220	40	1 1/2	204	204	65	19	87	140	51	70	200	250	3.6
R250P-270	50	2	225	225	74	23	87	146	57	70	200	250	4.4
R250P-550	50	2	426	397	83	22	132	224	76	70	200	250	12.3

Further documentation

- Overview "Valve-actuator combinations"
- Data sheets for actuators
- Installation instructions for pressure-independent characterised control valves and/or actuators, respectively
- General Notes for project planning