

Rotary actuator for butterfly valves

- Torque motor 160 Nm
- Nominal voltage AC 24...240 V / DC 24...125 V
- Control modulating, communicative, hybrid mode
- with 2 integrated auxiliary switches
- Conversion of sensor signals
- Communication via BACnet MS/TP, Modbus RTU, Belimo-MP-Bus or conventional control

Technical data

Electrical data	Nominal voltage	AC 24...240 V / DC 24...125 V
	Nominal voltage frequency	50/60 Hz
	Nominal voltage range	AC 19.2...264 V / DC 19.2...137.5 V
	Power consumption in operation	52 W
	Power consumption in rest position	7 W
	Power consumption for wire sizing	with 24 V 54 VA / with 230 V 68 VA
	Power consumption for wire sizing note	I _{max} 20 A @ 5 ms
	Auxiliary switch	2 x SPDT, 1 x 10° / 1 x 0...90° (ex works 85°)
	Switching capacity auxiliary switch	1 mA...3 (0.5 inductive) A, AC 250 V
	Connection supply	Terminals 2.5 mm ²
	Connection control	Terminals 1.5 mm ²
	Connection auxiliary switch	Terminals 2.5 mm ²
	Parallel operation	Yes (note the performance data)
Functional data	Nominal torque	160 Nm (parameterized for D6200W/WL)
	Communicative control	BACnet MS/TP (ex works) Modbus RTU MP-Bus
	Operating range Y	DC 2...10 V
	Input Impedance	100 kΩ
	Operating range Y variable	DC 0.5...10 V 4...20 mA
	Position feedback U	DC 2...10 V
	Position feedback U note	Max. 0.5 mA
	Position feedback U variable	DC 0.5...10 V
	Setting emergency setting position (POP)	0...100%, adjustable (ex works 0%)
	Bridging time (PF) variable	0...10 s (ex works 2s)
	Position accuracy	±5%
	Manual override	with hand crank, can be fixed in any position
	Running time motor	35 s / 90°
	Running time motor variable	30...120 s
	Running time emergency control position	30 s / 90°
	Sound power level Motor	68 dB(A)
	Sound power level emergency control position	61 dB(A)
	Position indication	Mechanically (integrated)
Safety	Protection class IEC/EN	II reinforced insulation
	Protection class UL	II reinforced insulation
	Protection class auxiliary switch IEC/EN	II reinforced insulation
	Degree of protection IEC/EN	IP66/67
	Degree of protection NEMA/UL	NEMA 4X, UL Enclosure Type 4X
	EMC	CE according to 2014/30/EU
	Low voltage directive	CE according to 2014/35/EU
	Certification IEC/EN	IEC/EN 60730-1 and IEC/EN 60730-2-14
	Certification UL	cULus according to UL60730-1A, UL60730-2-14 and CAN/CSA E60730-1:02
	Mode of operation	Type 1.AA
	Rated impulse voltage supply	4 kV
Rated impulse voltage control	0.8 kV	
Rated impulse voltage auxiliary switch	2.5 kV	

Technical data

Safety	Control pollution degree	3
	Ambient temperature	-30...50°C
	Non-operating temperature	-40...80°C
	Ambient humidity	Max. 95% r.h., non-condensing
	Maintenance	Maintenance-free
Mechanical data	Connection flange	F07 (F05 only with accessory)
Weight	Weight	8.5 kg
Terms	Abbreviations	POP = Power off position / emergency setting position CPO = Controlled power off / controlled emergency control function PF = Power fail delay time / bridging time

Safety notes



- This device has been designed for use in stationary heating, ventilation and air conditioning systems and must not be used outside the specified field of application, especially in aircraft or in any other airborne means of transport.
- Caution: Power supply voltage!
- Only authorised specialists may carry out installation. All applicable legal or institutional installation regulations must be complied during installation.
- Apart from the connection box, the device may only be opened at the manufacturer's site. It does not contain any parts that can be replaced or repaired by the user.
- The device contains electrical and electronic components and must not be disposed of as household refuse. All locally valid regulations and requirements must be observed.

Product features

Pre-charging time (start up)

The capacitor actuators require a pre-charging time. This time is used for charging the capacitors up to a usable voltage level. This ensures that, in the event of an electricity interruption, the actuator can move at any time from its current position into the preset emergency setting position (POP).

The duration of the pre-charging time depends mainly on following factors:

- Duration of the electricity interruption
- PF delay time (bridging time)

Typical pre-charging time

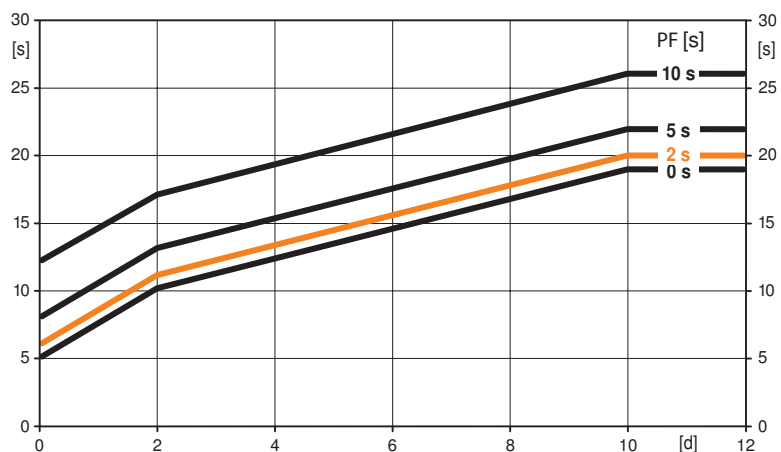

PF [s]	[d]				
	0	1	2	7	≥10
0	5	8	10	15	19
2	6	9	11	16	20
5	8	11	13	18	22
10	12	15	17	22	26

[d] = Electricity interruption in days
[s] = Pre-charging time in seconds
PF[s] = Bridging time

Calculation example: Given an electricity interruption of 3 days and a bridging time (PF) set at 5 s, the actuator requires a pre-charging time of 14 s after the electricity has been reconnected (see graphic).

Product features

Delivery condition (capacitors)	The actuator is completely discharged after delivery from the factory, which is why the actuator requires approximately 20 s pre-charging time before initial commissioning in order to bring the capacitors up to the required voltage level.
Converter for sensors	Connection option for two sensors (passive, active or switching contacts). In this way, the analogue sensor signal can be easily digitised and transferred to the bus systems BACnet or Modbus.
Parameterisable actuators	The factory settings cover the most common applications. The Belimo Assistant App is required for parameterisation via Near Field Communication (NFC) and simplifies commissioning. Moreover, it provides a variety of diagnostic options. The ZTH EU service tool provides a selection of both diagnostic and setting options.
Combination analogue - communicative (hybrid mode)	With conventional control by means of an analogue positioning signal, BACnet or Modbus can be used for the communicative position feedback
Simple direct mounting	Simple direct mounting on the butterfly valve. The mounting orientation in relation to the butterfly valve can be selected in 90° (angle) increments.
Manual override	The valve can be manually operated using a hand crank. Unlocking is carried out manually by removing the hand crank.
Internal heating	An internal heater prevents condensation buildup. Thanks to the integrated temperature and humidity sensor the built-in heater automatically switches on and off.
High functional reliability	The actuator is overload protected, requires no limit switches and automatically stops when the end stop is reached.
Setting emergency setting position (POP)	The desired emergency setting position (POP) can be set between 0 and 100% with the "Belimo Assistant App" or ZTH EU. The setting always refers to the adapted angle of rotation range. In the event of an electricity interruption, the actuator will move into the selected emergency setting position (POP).
Bridging time	Electricity interruptions can be bridged up to a maximum of 10 s. In the event of an electricity interruption, the actuator will remain stationary in accordance with the set bridging time. If the electricity interruption is greater than the set bridging time, then the actuator will move into the selected emergency setting position (POP). The pre-programmed bridging time is set to 2 s. This can be modified on site in operation with the use of the "Belimo Assistant App".
Flexible signalization	The actuator has one auxiliary switch with a fixed setting (10°) and one adjustable auxiliary switch (0...90°).

Accessories

	Description	Type
Gateways	Gateway MP for BACnet MS/TP, AC/DC 24 V	UK24BAC
	Gateway MP to Modbus RTU, AC/DC 24 V	UK24MOD
	Gateway MP to LonWorks, AC/DC 24 V, LonMark certified	UK24LON
	Gateway MP to KNX, AC/DC 24 V, EIBA certified	UK24EIB
	Description	Type
Electrical accessories	Connecting cable 5 m, A+B: RJ12 6/6, To ZTH EU	ZK1-GEN
	Description	Type
Mechanical accessories	Position indicator and tappet shaft, F07, square, SW 17	ZPR01
	Tappet shaft, F07, square, SW 17	ZPR02
	Position indicator and tappet shaft, F05, square, SW 14	ZPR03
	Retrofit adapter kit, F05/F07, flat head/ square, SW 17	ZPR05
	Retrofit adapter kit, F05/F07, square 45° turned, SW 14	ZPR06
	Retrofit adapter kit with ring, F07, square 45° turned, SW 17	ZPR08
	Retrofit adapter kit with ring, F07, flat head/ square, SW 14	ZPR09
	Retrofit adapter kit, F05/F07, flat head/ square, SW 14	ZPR10
	Retrofit adapter kit, F05/F07, square 45° turned, SW 18	ZPR11

Accessories

	Description	Type
	Retrofit adapter kit, F05/F07, flat head/ square, SW 16	ZPR12
	Hand crank for PR-actuator	ZPR20
Service Tools	Description	Type
	Smartphone app for easy commissioning, parameterising and maintenance	Belimo Assistant App
	Service tool for parametrisable and communicative Belimo actuators / VAV controller and HVAC performance devices	ZTH EU
Sensors	Description	Type
	Duct/Immersion Temperature Sensor 50 mm x 6 mm PT1000	01DT-1BH
	Duct/Immersion Temperature Sensor 50 mm x 6 mm Ni1000	01DT-1CH
	Duct/Immersion Temperature Sensor 100 mm x 6 mm PT1000	01DT-1BL
	Duct/Immersion Temperature Sensor 100 mm x 6 mm Ni1000	01DT-1CL
	Duct/Immersion Temperature Sensor 150 mm x 6 mm PT1000	01DT-1BN
	Duct/Immersion Temperature Sensor 150 mm x 6 mm Ni1000	01DT-1CN
	Duct/Immersion Temperature Sensor 200 mm x 6 mm PT1000	01DT-1BP
	Duct/Immersion Temperature Sensor 200 mm x 6 mm Ni1000	01DT-1CP
	Duct/Immersion Temperature Sensor 300 mm x 6 mm PT1000	01DT-1BR
	Duct/Immersion Temperature Sensor 300 mm x 6 mm Ni1000	01DT-1CR
	Duct/Immersion Temperature Sensor 450 mm x 6 mm PT1000	01DT-1BT
Duct/Immersion Temperature Sensor 450 mm x 6 mm Ni1000	01DT-1CT	

Electrical installation



Notes

- Caution: Power supply voltage!
- Parallel connection of other actuators possible. Observe the performance data.
- The main power supply for the actuator and for the auxiliary switches shall be from the same phase.
- The wiring of the line for BACnet MS/TP / Modbus RTU is to be carried out in accordance with applicable RS485 regulations.

Wiring diagrams

AC 24...240 V / DC 24...125 V Modulating control

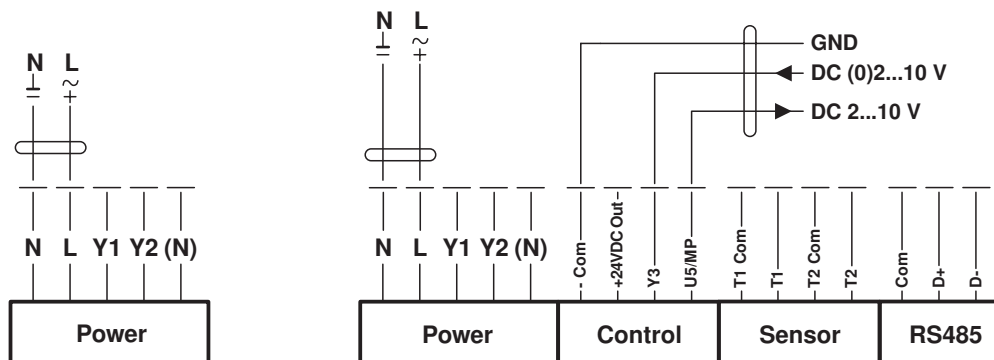

Electrical installation

Connection auxiliary switch

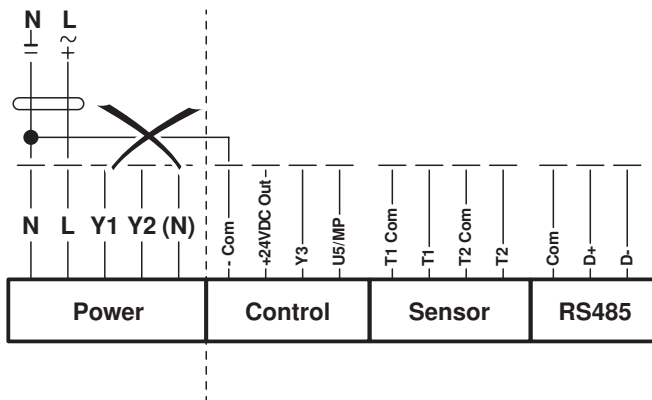
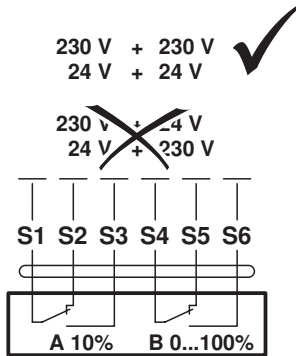

Power supply must not be connected to the signal terminals!

Follow-up control (position-dependent)

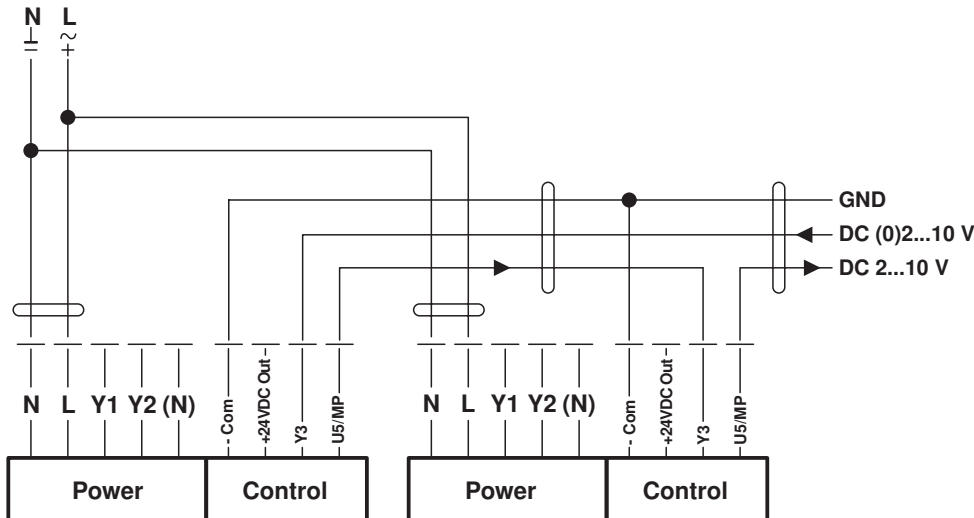

Functions

Functions for actuators with specific parameters (Parametrisation with NFC app necessary)

Control open-close

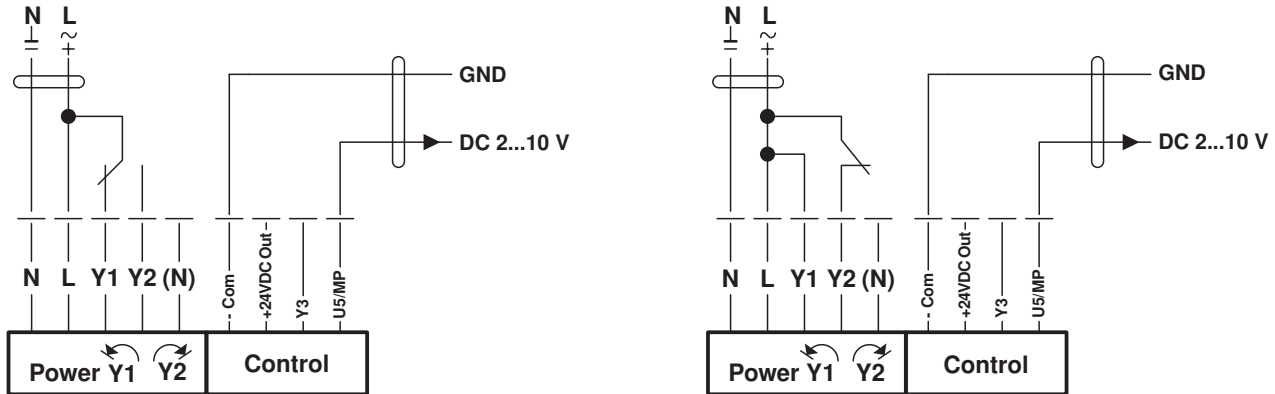

Control 3-point

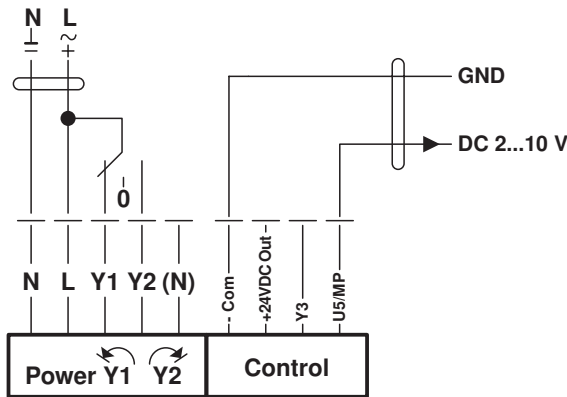

Control 4...20 mA

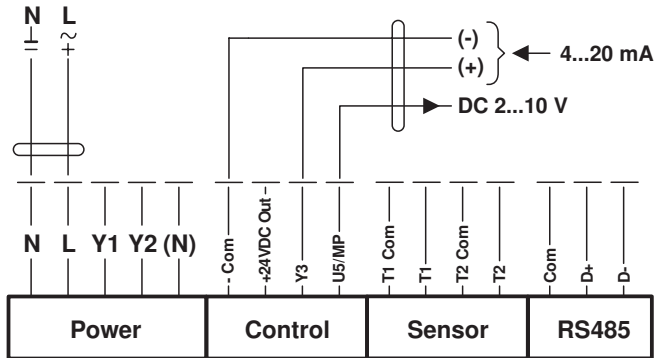

Positioner SG..

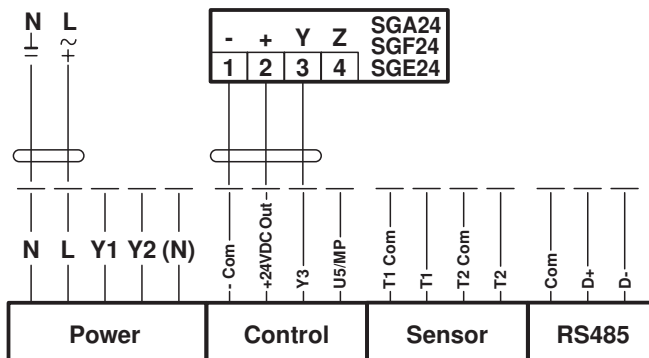

Note
Maximum output power «+ 24VDC out» 1.2 W @ 50 mA!
A separate safety transformer must be used for higher performance!

Functions

Connection on the MP-Bus

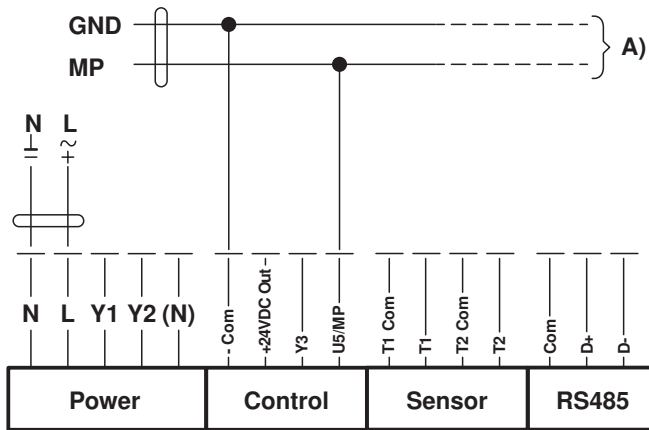

A) Additional actuators (max. 8)

Network topology

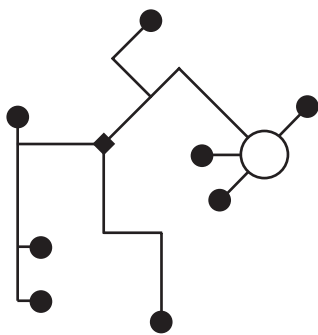

There are no restrictions for the network topology (star, ring, tree or mixed forms are permitted).
 Supply and communication in one and the same 3-wire cable
 • no shielding or twisting necessary
 • no terminating resistors required

Connection BACnet MS/TP / Modbus RTU with analog setpoint (hybrid mode)

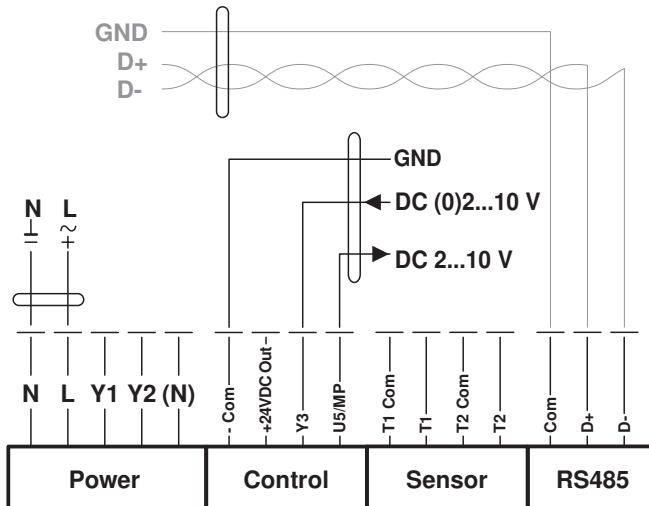

Functions

Connection BACnet MS/TP / Modbus RTU

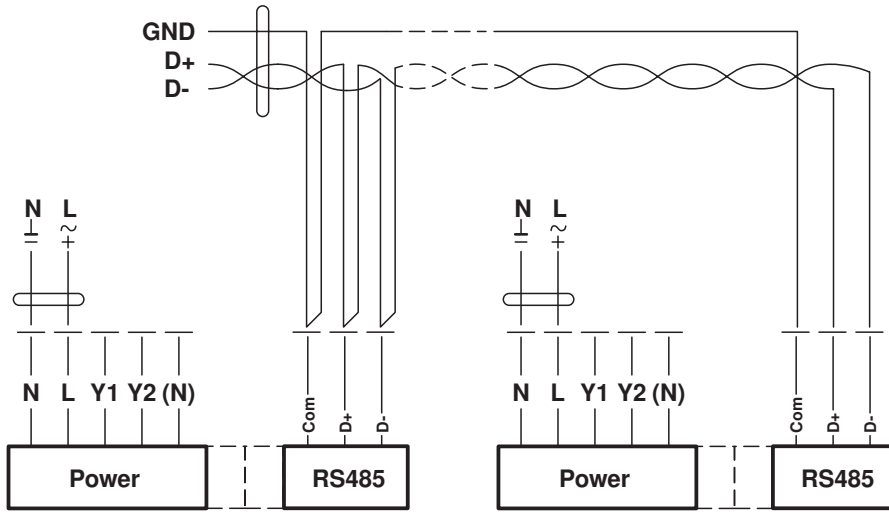

Connection of passive sensors (BACnet MS/TP / Modbus RTU)

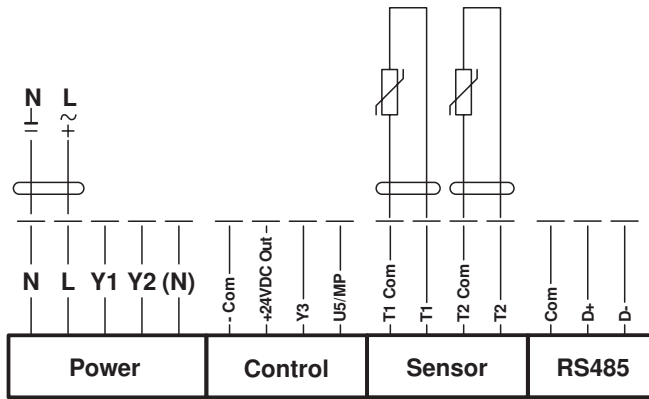

1)	2)
200 Ω...2 kΩ	0.1 Ω
2 kΩ...10 kΩ	1 Ω
10 kΩ...55 kΩ	10 Ω

- 1) Resistance range
- 2) Resolution
- Suitable for Ni1000 and PT1000
- Suitable Belimo types 01DT-...

Connection of active sensors (BACnet MS/TP / Modbus RTU)

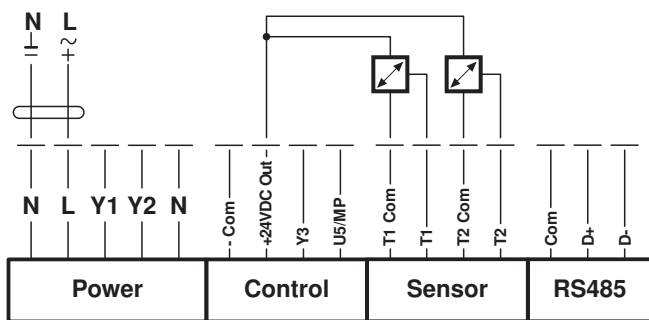

- Possible voltage range:
DC 0...10 V (resolution 5 mV)
For example, for the detection of:
- Active temperature sensors
 - Flow sensors
 - Pressure- / differential pressure sensors

Switching contact connection (BACnet MS/TP / Modbus RTU)

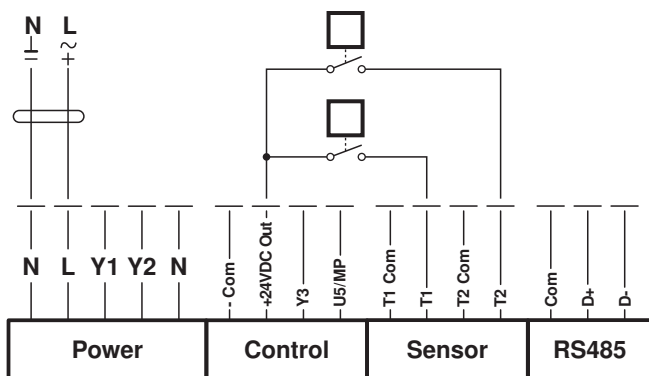

- Requirements for switching contact:
The switching contact must be able to accurately switch a current of 10 mA @ 24 V.
For example, for the detection of:
- Flow monitors
 - Operating- / fault messages from chillers

Operating controls and indicators

Auxiliary switch settings

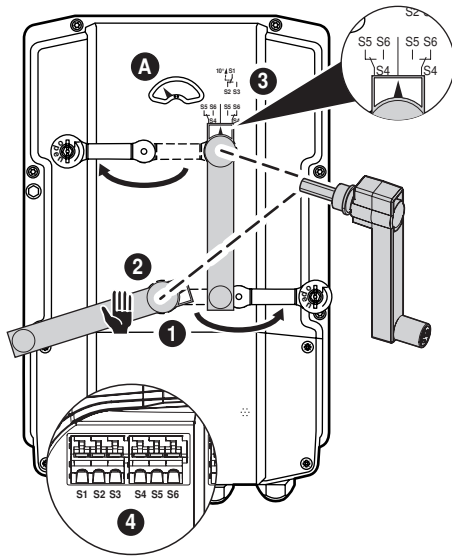

Note: Perform settings on the actuator only in deenergised state.

- 1 Gear disengagement**
Opening the manual override cover and adjusting the hand crank.
Manual override is possible.
- 2 Manual override control**
Turn the hand crank until the desired switching position **A** is indicated and then remove the crank.
- 3 Auxiliary switch**
Opening the auxiliary switch adjustment cover and adjusting the hand crank.
Turn the crank until the arrow points to the vertical line
- 4 Terminals**
Connect continuity tester to S4 + S5 or to S4 + S6.
If the auxiliary switch should switch in the opposite direction, rotate the hand crank by 180°.

Push-buttons and display

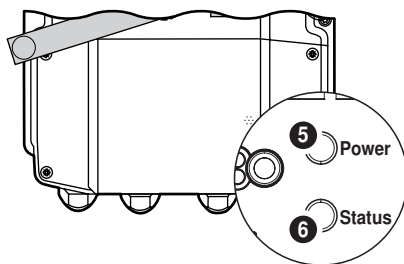

- 5 Push-button and LED display green**
Off: No power supply or malfunction
On: In operation
Press button: Triggers test run, followed by standard mode
- 6 Push-button and LED display yellow**
Off: Standard mode
On: Test run active
Flickering: BACnet / Modbus communication active
Flashing: Request for addressing from MP master
Press button: Confirmation of the MP addressing

Service

Service

NFC connection Belimo equipment marked with the NFC logo can be operated with the “Belimo Assistant App”.

Requirement:

- NFC- or Bluetooth-capable smartphone
- Belimo Assistant App (Google Play & App Store)

Align NFC-capable smartphone on the actuator so that both NFC antennas are superposed.

Connect Bluetooth-enabled smartphone via the Bluetooth-to-NFC Converter ZIP-BT-NFC to the actuator. Technical data and operation instructions are shown in the ZIP-BT-NFC data sheet.

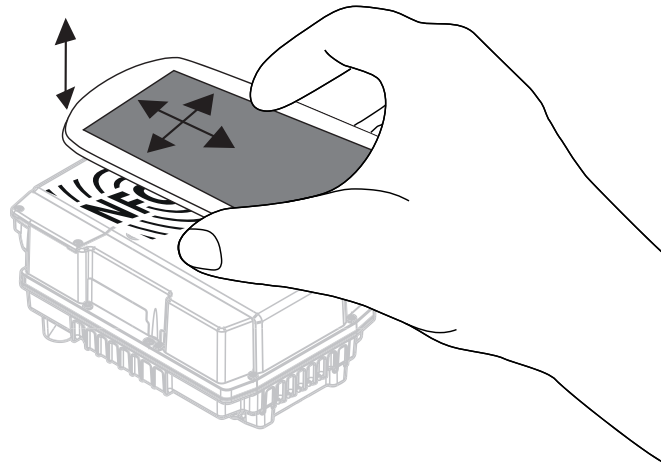

Service Tools connection The actuator can be parameterised by the ZTH EU via the service socket.

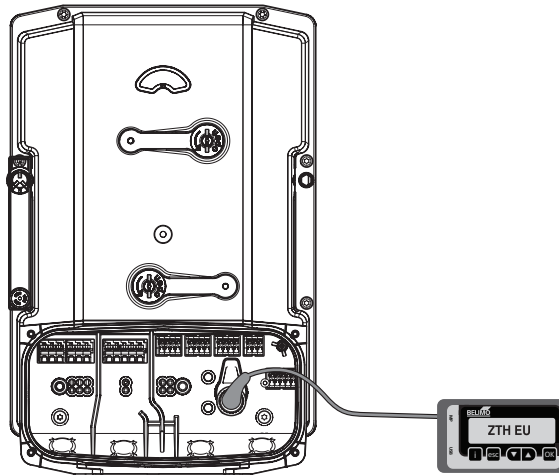

Dimensions [mm]

Dimensional drawings

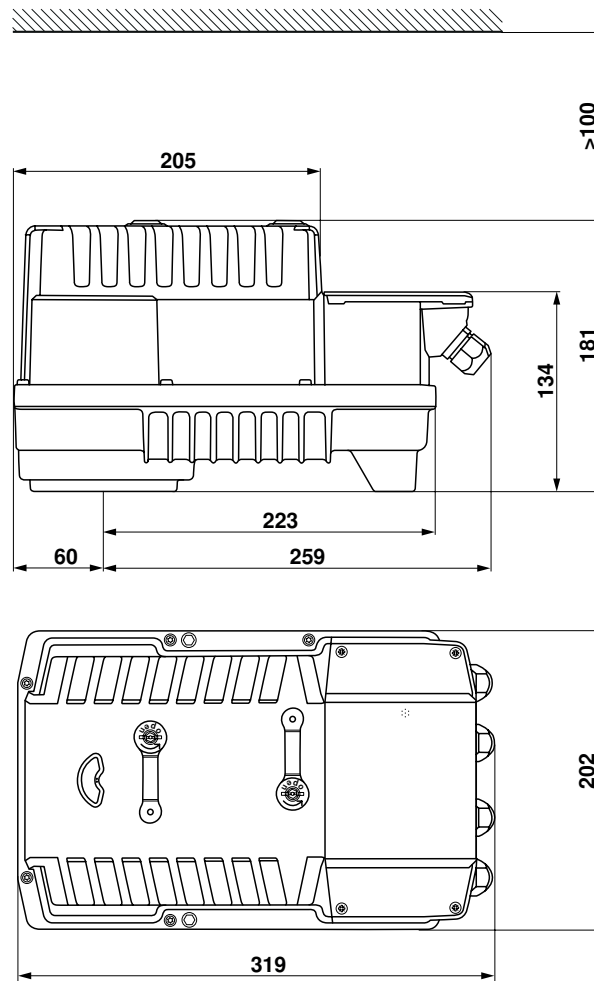

Further documentation

- Tool connections
- Description Protocol Implementation Conformance Statement PICS
- Description Modbus register
- Overview MP Cooperation Partners
- Introduction to MP-Bus Technology
- MP Glossary
- Overview Valve-actuator combinations
- Data sheets for butterfly valves
- Installation instructions for actuators and/or butterfly valves
- General notes for project planning