

## RS 300÷1200/E-EV BLU SERIES

The RS/E and RS/EV series burners are characterised by a modular monoblock structure that means all necessary components can be combined in a single unit thus making installation easier, faster and, above all, more flexible.

The burners cover a firing range from 1350 to 11100 kW, and they have been designed for use in hot water boilers or industrial steam generators.

Operation can be "two stage progressive" or alternatively "modulating" with the installation of a PID logic regulator on the RS/E series burners while RS/EV series is fully "modulating".

The mechanisms of regulation allow to catch up a high modulation ratio on all firing rates range.

The burner can, therefore, supply with precision the demanded power, guaranteeing an high efficiency system level and the stability setting, obtaining fuel consumption and operating costs reduction.

The burner operation can be intermittent or continuous by menu setting.

The innovative combustion head, adjustment system ensures perfect movement during modulation as well as reducing noise and pollutants.



RS 300/E BLU	500/1350 ÷ 3800 kW
RS 400/E BLU	800/1840 ÷ 4550 kW
RS 500/E BLU	1000/2500 ÷ 5170 kW
RS 650/E BLU	1410/3020 ÷ 6500 kW
RS 800/E BLU	1200/3500 ÷ 8100 kW
RS 300/EV BLU	500/1350 ÷ 3800 kW
RS 400/EV BLU	800/1840 ÷ 4550 kW
RS 500/EV BLU	1000/2500 ÷ 5170 kW
RS 650/EV BLU	1410/3020 ÷ 6500 kW
RS 800/EV BLU	1200/3500 ÷ 8100 kW
RS 1000/E-EV BLU	1100/4000 ÷ 10100 kW
RS 1200/E-EV BLU	1500/5500 ÷ 11100 kW

# Low NOx Modulating Gas Burners

## RS 300÷1200/E-EV BLU SERIES

### FIRING RATES

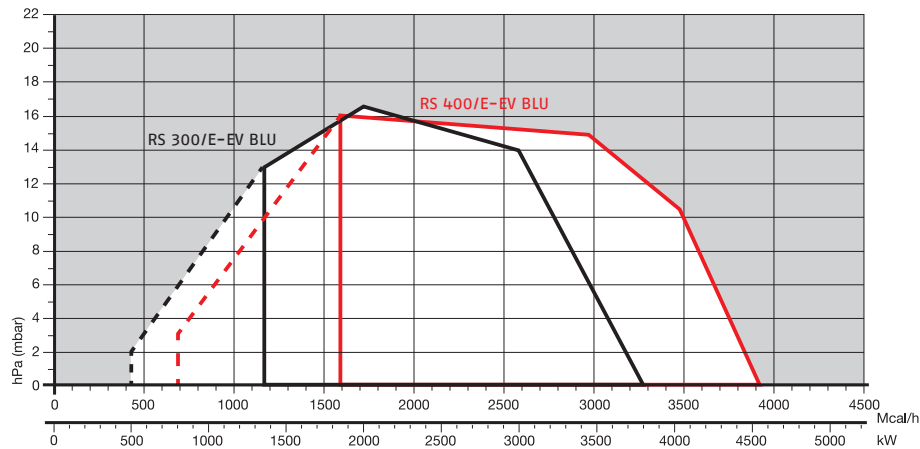

□ Useful working field for choosing the burner

▤ Modulation range

Test conditions conforming to EN676  
 Temperature: 20°C  
 Pressure: 1013,5 mbar  
 Altitude: 0 m a.s.l.

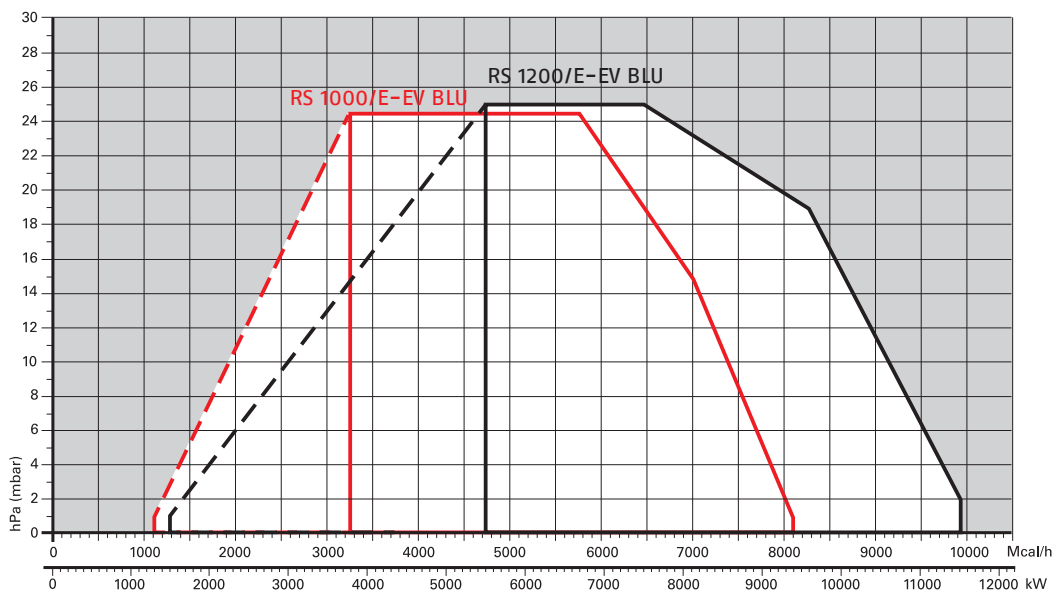
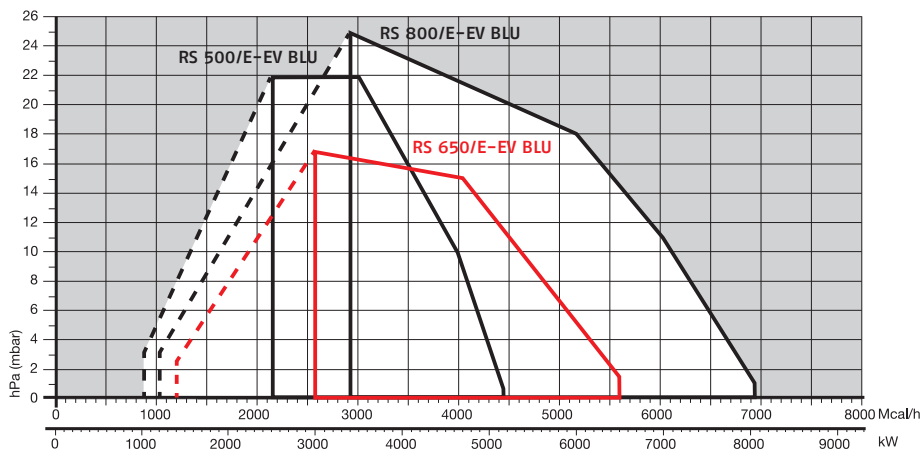

## Overall dimensions (mm)

### BURNER

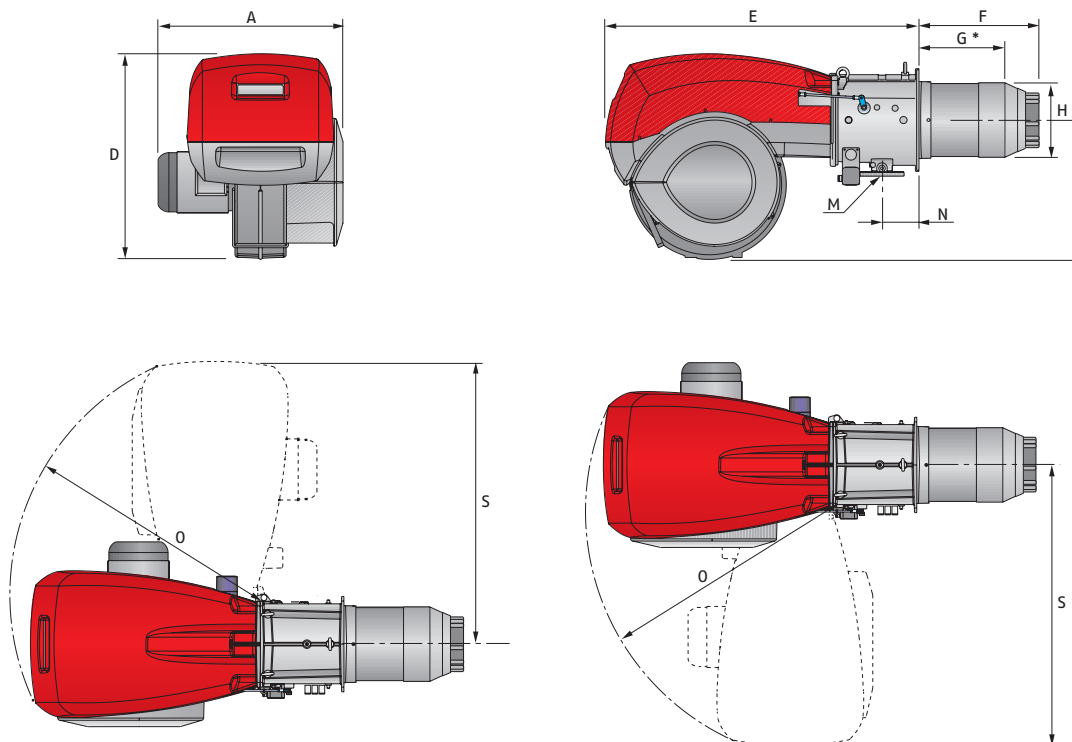

MODEL	A	D	E	F	G*	H	I	M	N	O	S
▶ RS 300/E-EV BLU	720	867	1325	521	373	313	588	DN65	164	1055	1175
▶ RS 400/E-EV BLU	775	867	1325	521	373	313	588	DN65	164	1055	1175
▶ RS 500/E-EV BLU	775	867	1325	521	357	370	588	DN65	164	1055	1175
▶ RS 650/E-EV BLU	800	950	1325	549	397	363	588	DN65/80	175	1055	1175
▶ RS 800/E-EV BLU	940	867	1325	582	418	363	588	DN65/80	164	1055	1175

\* Maximum depth of the boiler door including the depth of the burner flange insulating gasket.

### BURNER - BOILER MOUNTING FLANGE

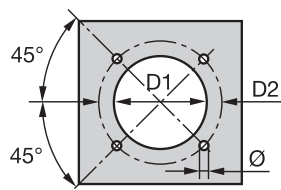

MODEL	D1	D2	Ø
▶ RS 300/E-EV BLU	350	452	M18
▶ RS 400/E-EV BLU	350	452	M18
▶ RS 500/E-EV BLU	390	452	M18
▶ RS 650/E-EV BLU	400	495	M18
▶ RS 800/E-EV BLU	400	495	M18

### PACKAGING

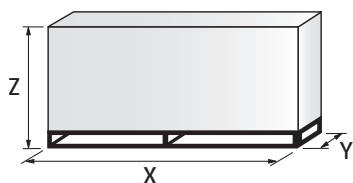

MODEL	X	Y	Z	kg
▶ RS 300/E-EV BLU	1960	945	1100	225
▶ RS 400/E-EV BLU	1960	945	1100	236
▶ RS 500/E-EV BLU	1960	945	1100	250
▶ RS 650/E-EV BLU	2040	1180	1125	300
▶ RS 800/E-EV BLU	2040	1180	1125	300

# Low NOx Modulating Gas Burners

## RS 300-1200/E-EV BLU SERIES

### Overall dimensions (mm)

#### BURNER

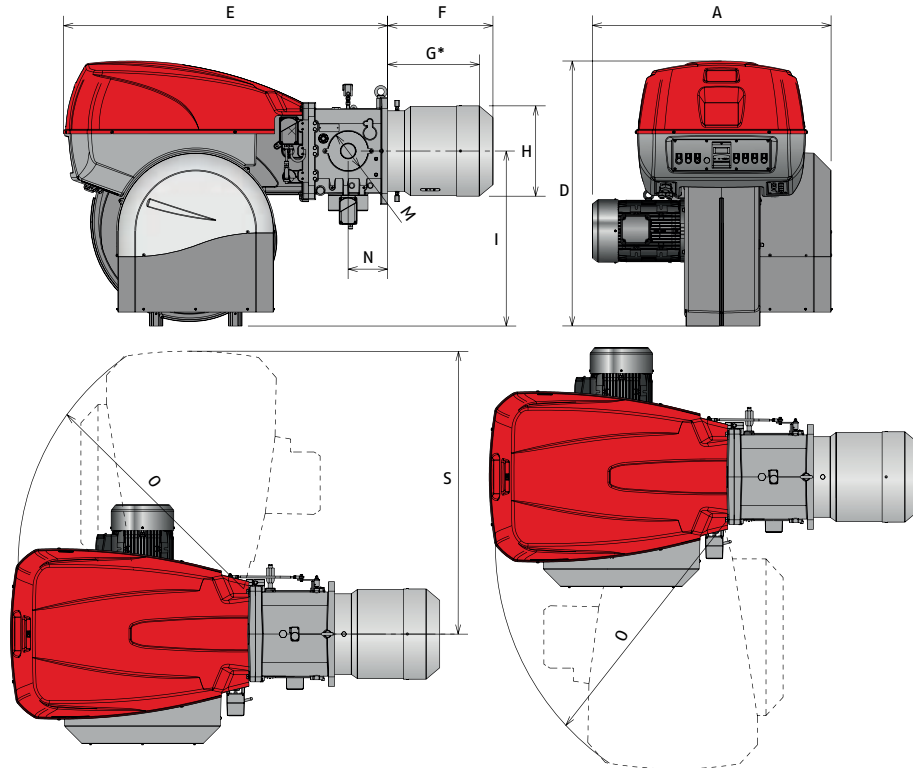

MODEL	A	D	E	F	G*	H	I	M	N	O	S
▶ RS 1000/E-EV BLU	1206	1338	1637	669	485	413	885	DN80	200	1350	1493
▶ RS 1200/E-EV BLU	1250	1338	1637	670	485	456	885	DN80	200	1350	1493

\* Maximum depth of the boiler door including the depth of the burner flange insulating gasket.

#### BURNER - BOILER MOUNTING FLANGE

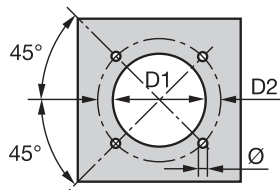

MODEL	D1	D2	Ø
▶ RS 1000/E-EV BLU	460	608	M20
▶ RS 1200/E-EV BLU	500	608	M20

#### PACKAGING

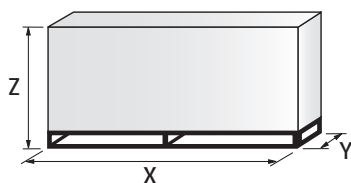

MODEL	X	Y	Z	kg
▶ RS 1000/E-EV BLU	2400	1400	1595	500
▶ RS 1200/E-EV BLU	2400	1400	1595	550

## RS 300÷1200/E-EV BLU SERIES

# Specification

## DESIGNATION OF SERIES

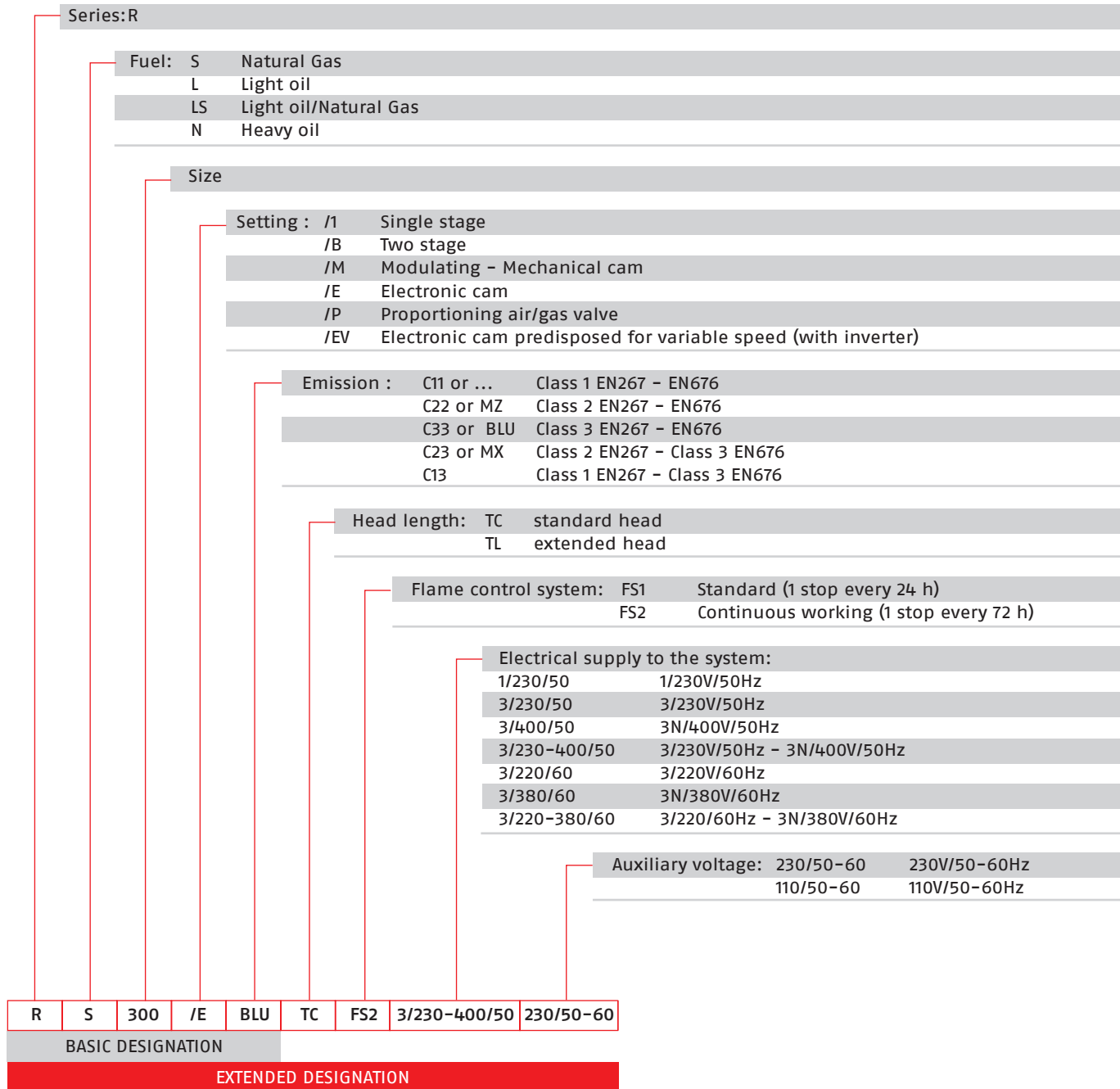

# Low NOx Modulating Gas Burners

## RS 300÷1200/E-EV BLU SERIES

### Specification

#### STATE OF SUPPLY

Monoblock forced draught gas burner with modulating operation, fully automatic, made up of:

- High performance fan with low sound emissions, reverse curve blades for RS 300-400-1000- 1200/E-EV BLU, forward curve blades for RS 500-650-800/E-EV BLU
- Air suction circuit lined with sound-proofing material
- Air damper for air setting controlled by a high precision servomotor
- Air pressure switch
- Fan starting motor at 2900 rpm, three-phase 230/400 - 400/690 V with neutral, 50Hz
- Low emission mobile combustion head, that can be set on the basis of required output, fitted with:
  - stainless steel end cone, resistant to corrosion and high temperatures
  - ignition electrodes
  - flame stability disk
- Automatic regulator for gas delivery, controlled by a high precision servomotor
- Maximum gas pressure switch, with pressure test point, for halting the burner in the case of over pressure on the fuel supply line
- Module for air/fuel setting and output modulation with separated PID control of temperature or pressure, available as accessory for RS 300-400-500-650-800/E BLU model
- Module for air/fuel setting and output modulation with incorporated PID control of temperature or pressure of the heat generator (RS/EV BLU and RS 1000-1200/E)
- AZL Display Interface, for combustion system commissioning and monitoring, included in RS/EV models and RS 1000-1200/E (Available as accessory for RS 300-400-500-650-800/E BLU models)
- Burner safety control included on Electronic Cam device
- Ionization probe for flame detector for RS 300-400-500-650-800 and IRD sensor for RS 1000-1200
- Star/triangle starter for the fan motor (burners with motor electrical power > = 7,5 kW, RS/E)
- Main electrical supply terminal board
- Burner on/off switch
- Auxiliary voltage led signal
- Manual or automatic output increase/decrease switch
- Burner working led signal
- Contacts motor and thermal relay with release button
- Motor internal thermal protection
- Motor failure led signal
- Burner failure led signal and lighted release button
- Emergency button
- Coded connection plugs-sockets
- Burner opening hinge
- Lifting rings
- IP 54 electric protection level
- The gas supply connector DN 80 for gas train connection (RS 300-400-500 models)

#### Standard equipment:

- 1 flange gasket
- 4 screws for fixing the flange
- 1 thermal screen
- 4 screws for fixing the burner flange to the boiler
- Seal control pressure switch (for installation on gas train)
- Instruction handbook for installation, use and maintenance
- Spare parts catalogue.

## RS 300÷1200/E-EV BLU SERIES

### Available models

#### Burners

CODE	MODEL					HEAT OUTPUT		TOTAL ELECTRICAL POWER (kW)	CERTIFICATION	NOTE
						(kW)	NATURAL GAS (Nm <sup>3</sup> /h)			
3898330	RS 300/E BLU	TC	FS1/FS2	3/230-400/50	230/50-60	500/1350÷3800	50/135÷380	6	CE 0085B00341	(1)(2)
3898430	RS 400/E BLU	TC	FS1/FS2	3/230/50	230/50-60	800/1840÷4550	80/184÷455	10	CE 0085B00341	(1)(2)
3898432	RS 400/E BLU	TC	FS1/FS2	3/400/50	230/50-60	800/1840÷4550	80/184÷455	10	CE 0085B00341	(1)(2)
3899130	RS 500/E BLU	TC	FS1/FS2	3/400/50	230/50-60	1000/2500÷5170	100/250÷517	11	CE 0085B00341	(1)(2)
20040218	RS 650/E BLU	TC	FS1/FS2	3/400/50	230/50-60	1410/3020÷6500	143/300÷655	21	CE 0085BT0337	(1)(2)
3911030	RS 800/E BLU	TC	FS1/FS2	3/400/50	230/50-60	1200/3500÷8100	120/350÷810	24	CE 0085BT0337	(1)(2)
20034426	RS 1000/E BLU	TC	FS1	3/400/50	230/50-60	1300/3800-9400	130/380-940	23	CE-0085CN0119	(1)
20034427	RS 1200/E BLU	TC	FS1	3/400/50	230/50-60	1500/5500-11500	150/550-1150	27	CE-0085CN0120	(1)
20057514	RS 1000/E BLU	TC	FS1	3/400/50	230/50-60	1300/3800-10100	130/380-940	23	CE-0085CN0119	(1)
20057515	RS 1200/E BLU	TC	FS1	3/400/50	230/50-60	1500/5500-11100	150/550-1150	27	CE-0085CN0120	(1)
3898350	RS 300/EV BLU	TC	FS1/FS2	3/230-400/50	230/50-60	500/1350÷3800	50/135÷380	6	CE 0085B00341	(1)(2)
3898452	RS 400/EV BLU	TC	FS1/FS2	3/400/50	230/50-60	800/1840÷4550	80/184÷455	10	CE 0085B00341	(1)(2)
3899152	RS 500/EV BLU	TC	FS1/FS2	3/400/50	230/50-60	1000/2500÷5170	100/250÷517	11	CE 0085BS0382	(1)(2)
20040547	RS 650/EV BLU	TC	FS1/FS2	3/400/50	230/50-60	1410/3020÷6500	143/300÷655	21	CE 0085BT0337	(1)(2)
3911090	RS 800/EV BLU	TC	FS1/FS2	3/400/50	230/50-60	1200/3500÷8100	120/350÷810	24	CE 0085BT0337	(1)(2)
20034429	RS 1000/EV BLU	TC	FS1	3/400/50	230/50-60	1300/3800-9400	130/380-940	23	CE-0085CN0119	(1)
20034430	RS 1200/EV BLU	TC	FS1	3/400/50	230/50-60	1500/5500-11500	150/550-1150	27	CE-0085CN0120	(1)
20057519	RS 1000/EV BLU	TC	FS1	3/400/50	230/50-60	1300/3800-10100	130/380-940	23	CE-0085CN0119	(1)
20057520	RS 1200/EV BLU	TC	FS1	3/400/50	230/50-60	1500/5500-11100	150/550-1150	27	CE-0085CN0120	(1)

Natural gas, net calorific value: 10 kWh/Nm<sup>3</sup> - Density: 0,71 kg/Nm<sup>3</sup>

(1) according to 2009/142 - 2006/42 - 2006/95 - 2004/108 EC Directives

(2) the burners are factory set for FS1 operation (1 stop every 24 h) but they can be switched to FS2 operation (continuous - 1 stop every 72 h) by changing the parameters through the AZL unit menu.

# Low NOx Modulating Gas Burners

## RS 300÷1200/E-EV BLU SERIES

### Available models

#### Gas Trains

CODE	GAS TRAIN		ADAPTER CODE		
	MODEL	∅	RS 300	RS 400	RS 500
3970250*	MB 415/1 - RT 52	Rp 1" ½	20064220 + 20064169 / (20064220 + 3000826 + 3010221 + 20059330) <sup>1</sup>	●	●
3970257*	MB 420/1 - RT 52	Rp 2"	20042324 + 20064169 / (20042324 + 3000826 + 3010221 + 20059330) <sup>1</sup>	●	●
3970221*	MBC 1200/1 - RSM 60	Rp 2"	20042324 + 20064169 / (20042324 + 3000826 + 3010221 + 20059330) <sup>1</sup>		
3970222*	MBC 1900/1 - FSM 40	DN 65	20059330 / (20065924 + 20059330) <sup>1</sup>		
3970223*	MBC 3100/1 - FSM 40	DN 80	20059331 / (20065937 + 20059331) <sup>1</sup>		
3970224*	MBC 5000/1 - FSM 80	DN 100	20059332 / (20065960 + 20059332) <sup>1</sup>		
3970145*	CB 512/1 - RSM 30	Rp 1" ½	20064220 + 20064169 / (20064220 + 3000826 + 3010221 + 20059330) <sup>1</sup>		●
3970146*	CB 520/1 - RSM 30	Rp 2"	20042324 + 20064169 / (20042324 + 3000826 + 3010221 + 20059330) <sup>1</sup>		
20044659*	CB 525/1 - RSM 30	Rp 2"	20042324 + 20064169 / (20042324 + 3000826 + 3010221 + 20059330) <sup>1</sup>		
3970147*	CB 5065/1 - FSM 30	DN 65	20059330 / (20065924 + 20059330) <sup>1</sup>		
3970148*	CB 5080/1 - FSM 30	DN 80	20059331 / (20065937 + 20059331) <sup>1</sup>		
3970149*	CB 50100/1 - FSM 30	DN 100	20059332 / (20065960 + 20059332) <sup>1</sup>		
20015871*	CB 50125/1 - FSM 30	DN 125	20059333 / (20065968 + 20059333) <sup>1</sup>		

CODE	GAS TRAIN		ADAPTER CODE			
	MODEL	∅	RS 650	RS 800	RS 1000	RS 1200
3970221*	MBC 1200/1 - RSM 60	Rp 2"	20042324 + 20064169 / (20042324 + 3000826 + 3010221 + 20059330) <sup>1</sup>		20042324 + 20066253 / (20042324 + 3000826 + 3010221 + 20066263) <sup>1</sup>	
3970222*	MBC 1900/1 - FSM 40	DN 65	20059330 / (20065924 + 20059330) <sup>1</sup>		20066263 / (20065924 + 20066263) <sup>1</sup>	
3970223*	MBC 3100/1 - FSM 40	DN 80	20059331 / (20065937 + 20059331) <sup>1</sup>		20066268 / (20065937 + 20066268) <sup>1</sup>	
3970224*	MBC 5000/1 - FSM 80	DN 100	20059332 / (20065960 + 20059332) <sup>1</sup>		20066278 / (20065960 + 20066278) <sup>1</sup>	
20044659*	CB 525/1 - RSM 30	Rp 2"	20042324 + 20064169 / (20042324 + 3000826 + 3010221 + 20059330) <sup>1</sup>	●	●	●
3970147*	CB 5065/1 - FSM 30	DN 65	20059330 / (20065924 + 20059330) <sup>1</sup>		20066263 / (20065924 + 20066263) <sup>1</sup>	●
3970148*	CB 5080/1 - FSM 30	DN 80	20059331 / (20065937 + 20059331) <sup>1</sup>		20066268 / (20065937 + 20066268) <sup>1</sup>	
3970149*	CB 50100/1 - FSM 30	DN 100	20059332 / (20065960 + 20059332) <sup>1</sup>		20066278 / (20065960 + 20066278) <sup>1</sup>	
20015871*	CB 50125/1 - FSM 30	DN 125	20059333 / (20065968 + 20059333) <sup>1</sup>		20066284 / (20065968 + 20066284) <sup>1</sup>	

Please see designation of Gas Train Series in the page before the Catalogue index.

\* 230V/50Hz -220V/60Hz electrical supply.

\*\* 230V/50Hz electrical supply.

The valve seal control device is compulsory (conforming to EN 676) on gas trains to burners with a maximum output over 1200 kW.

To select the gas train please refer to the technical data leaflet and/or instruction manual.

C.T. Gas valve leak detection control device:

- gas train not equipped with leak detection control device; this device can be ordered separately - see VPS column - and installed later.

VPS Valve leak detection control device. Supplied separately from the gas train (please see Gas train accessories paragraph for both 50 Hz and 60 Hz codes).

● Not available.

1) To be used with gas train and burner opening on the left (fan motor side).



## RS 300÷1200/E-EV BLU SERIES

### Burner accessories

#### Extended head kit

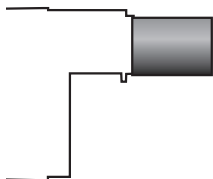

“Standard head” burners can be transformed into “extended head” versions, by using the special kit. The KITS available for the various burners, giving the original and the extended lengths, are listed below.

BURNER	STANDARD HEAD LENGTH (mm)	EXTENDED HEAD LENGTH (mm)	KIT CODE
▶ RS 300-400/E-EV BLU	521 (1) - 373 (2)	621 (1) - 473 (2)	3091427
▶ RS 300-400/E-EV BLU	521 (1) - 373 (2)	671 (1) - 523 (2)	3091919
▶ RS 300-400/E-EV BLU	521 (1) - 373 (2)	721 (1) - 573 (2)	20022815
▶ RS 500/E-EV BLU	521 (1) - 357 (2)	671 (1) - 507 (2)	20028449

(1) referred to quote F  
(2) referred to quote G

#### Variable Speed Drive (VSD) for RS/EV series only



The motor speed variation for the RS/EV BLU burners series is obtained thanks to a frequency converter: variable speed drive (VSD). It always must be ordered with RS/EV series.

BURNER	MAX POWER (kW)	KIT CODE
▶ RS 300-400/EV BLU	7,5	20028307
▶ RS 500/EV BLU	11	3090952
▶ RS 650/EV BLU	18,5	3091174
▶ RS 800-1000/EV BLU	22	3090913
▶ RS 1200/EV BLU	30	20030338

#### Accessories for modulating operation



To obtain modulating operation, the RS/E BLU series of burners requires a regulator with three point outlet controls. The following table lists the accessories for modulating operation with their application range. In RS/EV models PID regulator is integrated inside LMV 52 control box.

BURNER	POWER CONTROLLER TYPE	CODE
▶ All models	RWF 40 - Basic version with 3 position output	3010356
	RWF 40 - High version with additional modulating output and RS 485 Interface	3010357

The relative temperature or pressure probes fitted to the regulator must be chosen on the basis of the application.



BURNER	PROBE TYPE	RANGE (°C) (bar)	CODE
▶ All models	Temperature PT 100	-100 ÷ 500°C	3010110
	Pressure 4 ÷ 20 mA	0 ÷ 2,5 bar	3010213
	Pressure 4 ÷ 20 mA	0 ÷ 16 bar	3010214
	Pressure 4 ÷ 20 mA	0 ÷ 25 bar	3090873

# Low NOx Modulating Gas Burners

## RS 300÷1200/E-EV BLU SERIES

### Burner accessories

#### Display and Operating Unit (AZL) for RS/E models



This tool is needed for combustion system commissioning and monitoring. The AZL, Display and Operating Unit, is included in RS/EV and RS1000-1200/E-EV models.

BURNER	KIT CODE
▶ RS 300-400-500-650-800/E BLU	3010355
▶ All models *	3010469

\* for Russian language only

#### Infrared Flame Detector (IFD)



For the supervision of gas, oil or other flame that emit infrared radiation, the RS/E-EV BLU series of burners can be equipped with infrared flame detector. The infrared flame detector are suited for burners of any capacity, either in continuous or intermittent operation.

BURNER	CODE
▶ All models	3010354

#### Oxygen Control kit (QGO<sub>2</sub>) for RS/EV series only



The QGO<sub>2</sub> is an oxygen analyzer with relevant probe which controls and supervises the residual oxygen content in exhaust gases.

BURNER	KIT CODE
▶ All models	3010378
▶ All models	20045187*

\* Installation outside the burner cover

#### Kit efficiency with oxygen control kit (for RS/EV only)

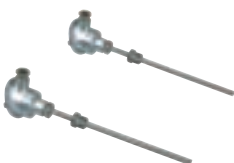

The kit includes two temperature sensors: one for air and one for exhaust gas detection. They must be wired to oxygen control kit interface to allow the LMV 52 efficiency calculation. The value is showed on AZL display.

BURNER	KIT CODE
▶ All models	3010377

## Burner accessories

### PC Interface Software (ACS 450)



PC tool for convenient programming and burner settings, process visualization, data recording, selection of AZL language, software update AZL.

BURNER	CODE
► All models	3010388

### Sound proofing box

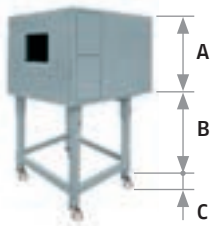

If noise emission needs reducing even further, sound-proofing boxes are available. In case of generator heights, where a lower dimension "B" is required, ask for the Box Support Kit code 20065135.

BURNER	BOX TYPE	A (mm)	B (mm) min-max	C (mm)	[dB(A)] (*)	BOX CODE
► RS 300-400-500-650-800/E-EV BLU	C7	1255	160 - 980	110	10	3010376
► RS 1000-1200/E-EV BLU	C8	1425	285 - 1000	110	10	3010401

(\*) Average noise reduction according to EN 15036-1 standard

### LPG kit



For burning LPG gas, a special kit is available to be fitted to the combustion head of the burner.

BURNER	KIT CODE
► RS 300/E-EV BLU	3010445 (*)
► RS 400-500/E-EV BLU	20012916 (*)
► RS 650/E-EV BLU	in progress
► RS 800/E-EV BLU	20007822 (*)

(\*) CE approved.

### Continuous ventilation kit



If the burner requires continuous ventilation in the stages without flame, a special kit is available as given in the following table:

BURNER	KIT CODE
► All models	3010094

### Spacer kit



If burner head penetration into the combustion chamber needs reducing, varying thickness spacers are available, as given in the following table:

BURNER	SPACER THICKNESS S (mm)	KIT CODE
► RS 300-400-500-650-800/E-EV BLU	180	20008903



# Low NOx Modulating Gas Burners

## RS 300÷1200/E-EV BLU SERIES

### Gas train accessories

#### Adapters

In certain cases, an adapter must be fitted between the gas train and the burner, when the diameter of the gas train is different from the set diameter of the burner. Below are given the available adapters; please see on the Gas Train list the correct adapter codes to select.

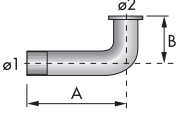
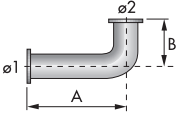
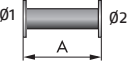
ADAPTER	DIMENSIONS				ADAPTER CODE
	Ø1 DN	Ø2 DN	A mm	B mm	
 1" 1/2" 2"	-	-	65	-	20064220
 2" 2"	-	-	65	-	20042324
 DN 80 2" 1/2" 2"	-	-	300	-	3000826
	2"	65 / 80	230	230	20064169
	65	65 / 80	230	230	20059330
	80	65 / 80	230	230	20059331
	100	65 / 80	230	230	20059332
	125	65 / 80	245	230	20059333
	2"	65 / 80	230	375	20066253
	65	65 / 80	230	375	20066263
	80	65 / 80	230	375	20066268
	100	65 / 80	230	375	20066278
	125	65 / 80	245	375	20066284
	65	80	400	-	3010221
	80	80	400	-	3010222
	100	80	400	-	3010223
	125	80	320	-	3010224
	65	65	800	-	20065924
	80	80	800	-	20065937
	100	100	800	-	20065960
125	125	800	-	20065968	

**RS 300÷1200/E-EV BLU SERIES**

**Gas train accessories**

**Stabiliser spring**



To vary the pressure range of the gas train stabilisers, accessory springs are available. The following table shows these accessories with their application range. Please refer to the technical manual for the correct choice of spring.

GAS TRAIN	SPRING COLOUR	SPRING PRESSURE RANGE mbar	SPRING CODE
▶ MBC 1900/1 - 3100/1 MBC 5000/1	White	4 - 20	3010381
	Red	20 - 40	3010382
	Black	40 - 80	3010383
	Green	80 - 150	3010384
▶ CB 512/1	Red	25 - 55	3010131
	Black	60 - 110	3010157
	Pink	90 - 150	3090486
▶ CB 520/1 - 525/1	Red	25 - 55	3010132
	Black	60 - 110	3010158
	Pink	90 - 150	3090487
▶ CB 5065/1 - 5080/1	Red	25 - 55	3010133
	Black	60 - 110	3010135
	Pink	100 - 150	3090456
	Grey	140 - 200	3090992
▶ CB 50100/1	Red	25 - 55	3010134
	Black	60 - 110	3010136
	Pink	100 - 150	3090489
▶ CB 50125/1	Grey	140 - 200	3092174
	Red	25 - 55	3010315
	Yellow	30 - 70	3010316
	Black	60 - 110	3010317
	Pink	100 - 150	3010318