

TS0077UK02

RS 300÷800/M BLU Series

Low NOx Modulating Gas Burners



RS 300/M BLU	500/1350 ÷ 3800 kW
RS 400/M BLU	950/1830 ÷ 4590 kW
RS 500/M BLU	1000/2500 ÷ 5170 kW
RS 800/M BLU	1200/3500 ÷ 8100 kW

The RS 300-400-500-800/M BLU burners are characterised by a monoblock structure which means that all necessary components are combined in a single unit, making installation easier and faster.

The burners cover a firing range from 1350 to 8100 kW, and it have been designed for use in hot water boilers or industrial steam generators.

Operation can be “two stage progressive” or alternatively “modulating” with the installation of a PID logic regulator or by external 4-20 mA/0-10 V signal.

The mechanical cam device of regulation allows to catch up a high modulation ratio on all firing rates range. The burners can, therefore, supply with precision the demanded power, guaranteeing a high efficiency system level and the stability setting, obtaining fuel consumption and operating costs reduction.

The combustion head, engineered with advanced simulation devices, guarantees reduced polluting emissions (NOx < 80 mg/kWh). FS1 and FS2 versions are available for intermittent and continuous operation applications.

An exclusive design, with reverse blade fan, guarantees low sound emissions, low electrical consumption, easy use and maintenance.

Technical Data

MODEL		RS 300/M BLU	RS 400/M BLU	RS 500/M BLU	RS 800/M BLU
Burner operation mode		Modulating			
Modulation ratio at max. output		5 ÷ 1			
Servomotor	type	Modificatore: LKS 310 (FS1 version) - SQM 10 (FS2 version)			
	run time s	--			
Heat output	kW	500/1350÷3800	950/1830÷4590	1000/2500÷5170	1200/3500÷8100
	Mcal/h	430/1161÷3268	688/1548÷3870	860/2150÷4470	1032/3010÷6966
Working temperature	°C min./max.	0/60			
FUEL/AIR DATA					
Net calorific value G20 gas	kWh/Nm ³	10			
G20 gas density	kg/Nm ³	0,71			
G20 gas delivery	Nm ³ /h	50/135÷380	80/180÷450	100/250÷520	120/350÷80
Net calorific value G25 gas	kWh/Nm ³	8,6			
G25 gas density	kg/Nm ³	0,78			
G25 gas delivery	Nm ³ /h	58/156÷442	93/209÷523	116/290÷605	139/407÷942
Net calorific value LPG gas	kWh/Nm ³	25,8			
LPG gas density	kg/Nm ³	2,02			
LPG gas delivery	Nm ³ /h	--			
Fan	type	Reverse curve blades		Forward curve blades	
Air temperature	max °C	60			
ELECTRICAL DATA					
Electrical supply	Ph/Hz/V	3N/50/230-400 (±10%)	3N/50/400 (±10%)	3N/50/400 (±10%)	
Auxiliary electrical supply	Ph/Hz/V	1/50/230 ~ (±10%)			
Control box	type	RMG/M (for intermittent operation) - LGK16 (for continuous operation)			
Total electrical power	kW	6	9	10,5	25
Auxiliary electrical power	kW	--			
Protection level	IP	54			
Motor electrical power	kW	4,5	7,5	9,2	21
Rated motor current	A	15,8 - 9,1	23 - 16	18	39,6
Motor start up current	A	7 x In		8,1 x Nom	6 x Nom
Motor protection level	IP	54		55	
Ignition transformer	type	--			
	V1 - V2	230V - 1x8 kV			
	I1 - I2	1A - 20mA			
Operation		Intermittent version (at least one stop every 24 h) or Continuous version (at least one stop every 72 h)			
EMISSIONS					
Sound pressure	dB (A)	82	85	87	88
Sound power	W	--			
CO emission	mg/kWh	< 10			
NOx emission	mg/kWh	< 80			
APPROVAL					
Directive		90/396 - 89/336 (2004/108) - 73/23 (2006/95) EC			
Conforming to		EN 676			
Certification		CE 0085B00341			in progress

Reference conditions:

Temperature: 20°C - Pressure: 1013,5 mbar - Altitude: 0 m a.s.l. - Noise measured at a distance of 1 meter.

Since the Company is constantly engaged in the production improvement, the aesthetic and dimensional features, the technical data, the equipment and the accessories can be changed. This document contains confidential and proprietary information of RIELLO S.p.A. Unless authorised, this information shall not be divulged, nor duplicated in whole or in part.

FIRING RATES

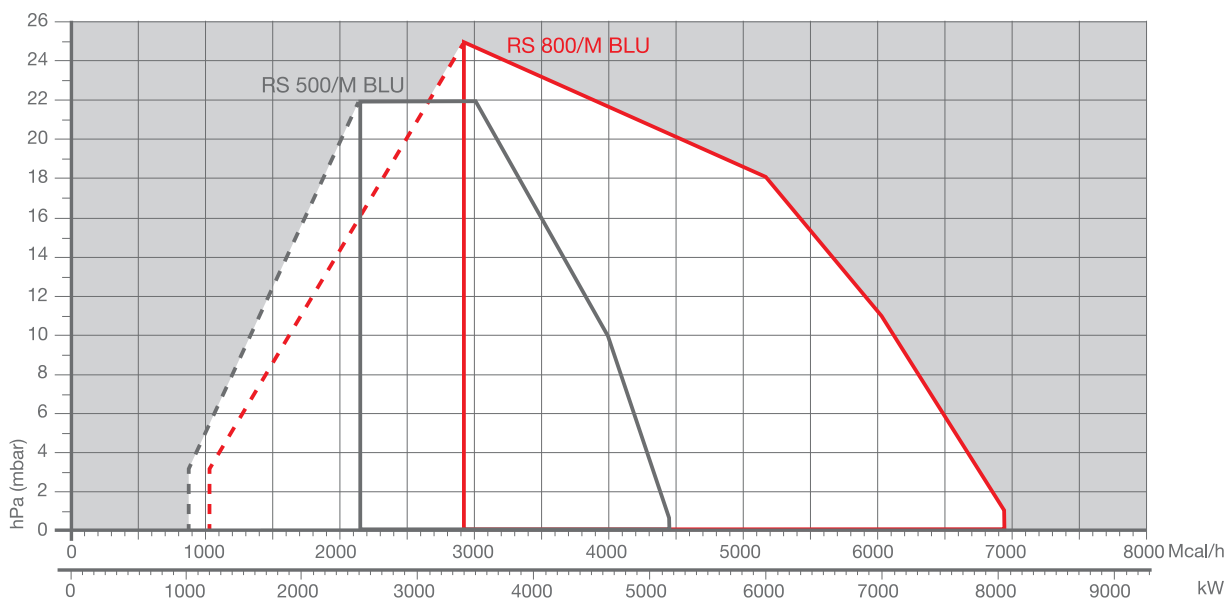
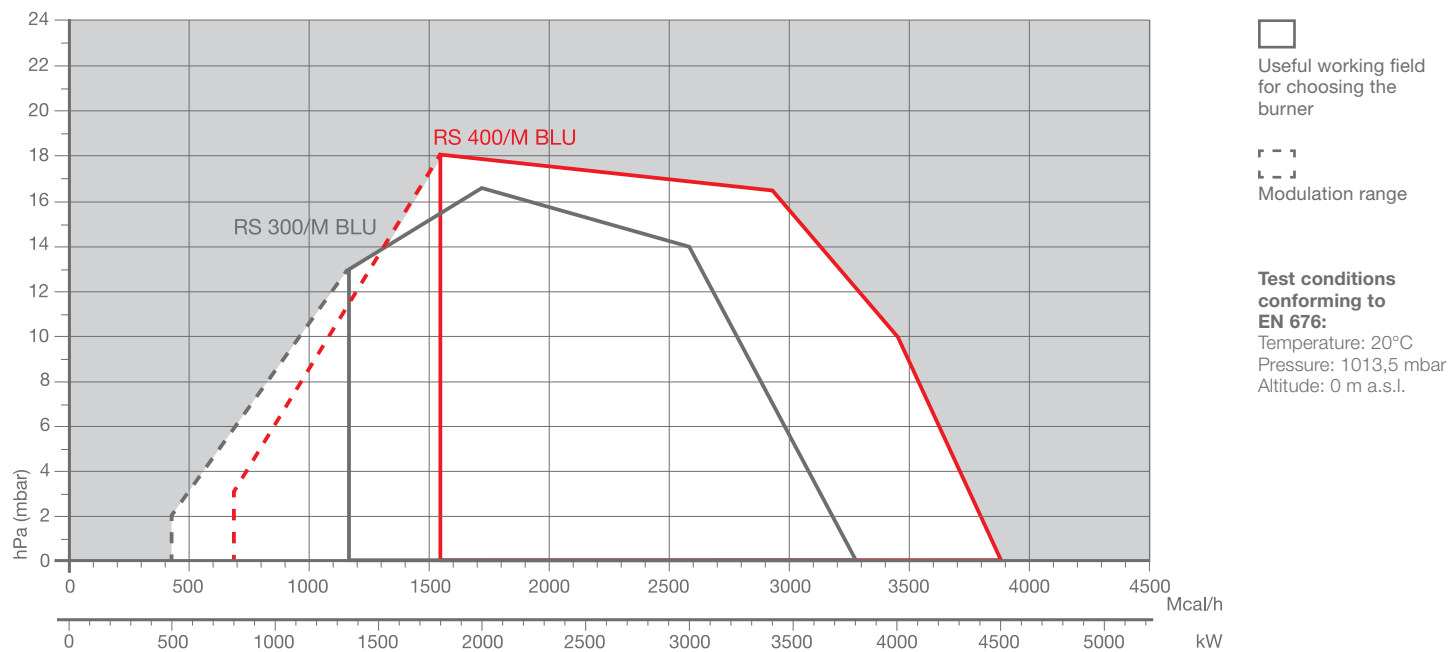



GAS TRAINS

The burners are fitted with a butterfly valve to regulate the fuel, controlled by the main management module of burner through a high precision servomotor.

Fuel can be supplied either from the right or left sides, on the basis of the application requirements.

A maximum gas pressure switch stops the burner in case of excess pressure in the fuel line.

The gas train can be selected to best fit system requirements depending on the fuel output and pressure in the supply line.

The gas trains are "Multibloc" and "Composed" type (assembly of the single components) with or without seal control.

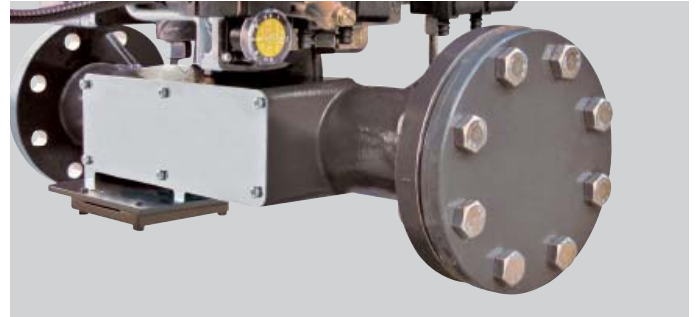

Example of RS 300-400-500/M BLU gas adjustment butterfly valve.

MULTIBLOC gas train type MBC 1200

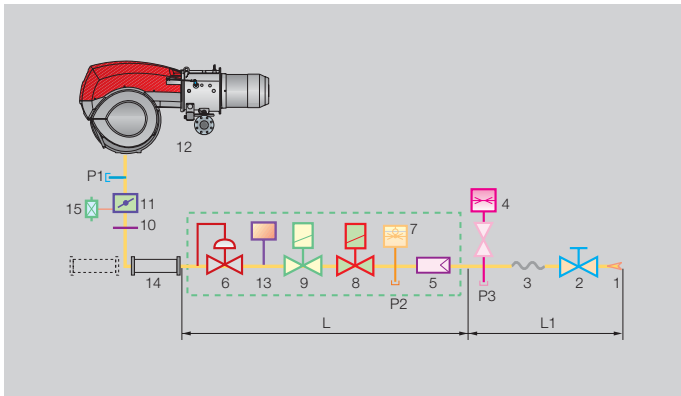

COMPOSED gas train type MBC 1900 - 3100 - 5000

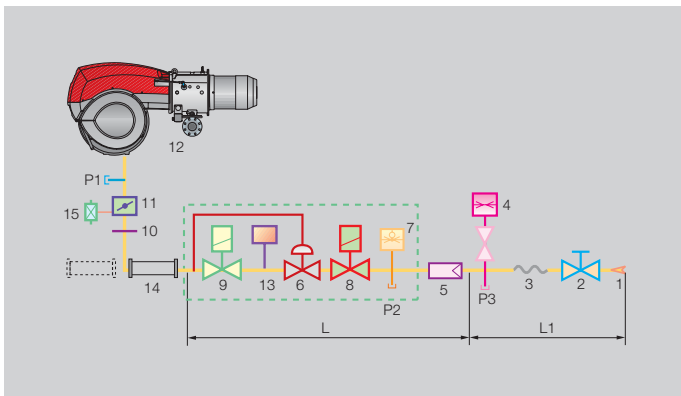

- | | |
|----|------------------------------------------------------------------------------------------------------------------------------------------------------|
| 1 | Gas input pipework |
| 2 | Manual valve |
| 3 | Anti-vibration joint |
| 4 | Pressure gauge with pushbutton cock |
| 5 | Filter |
| 6 | Pressure regulator (vertical) |
| 7 | Minimum gas pressure switch |
| 8 | VS safety solenoid (vertical) |
| 9 | VR regulation solenoid (vertical) |
| 9 | Two settings: - firing output (rapid opening)
- maximum output (slow opening) |
| 10 | Gasket and flange supplied with the burner |
| 11 | Gas adjustment butterfly valve |
| 12 | Burner |
| 13 | Seal control mechanism for valves 8-9.
According to standard EN 676, the seal control is compulsory for burners with maximum output above 1200 kW |
| 14 | Gas train-burner adapter |
| 15 | Maximum gas pressure switch |
| P1 | Combustion head pressure |
| P2 | Pressure downstream from the regulator |
| P3 | Pressure upstream from the filter |
| L | Gas train supplied separately, with the code given in the table |
| L1 | Installer's responsibility |

Gas trains are approved by standard EN 676 together with the burner.

The overall dimensions of the gas train depends on how they are constructed. The following table shows the maximum dimensions of the gas trains that can be fitted to RS 300-400-500-800/M BLU burners, intake and outlet diameters and seal control if fitted. The maximum gas pressure of gas train "Multibloc" type is 360 mbar, and that one of gas train "Composed" type is 500 mbar. MULTIBLOC guarantees a range of pressure towards the burner from 3 to 60 mbar. For version DN 65 and DN 80 is from 20 to 40 mbar. The range of pressure in the MULTIBLOC with flange can be modified choosing the stabiliser spring (see gas train accessory).

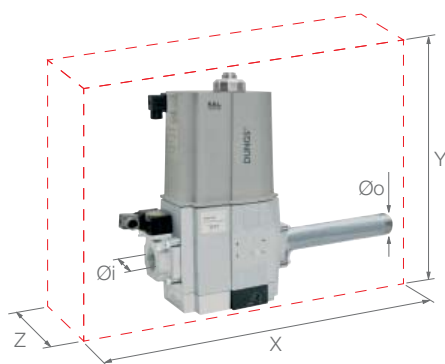

Example of gas train "MULTIBLOC" type without seal control

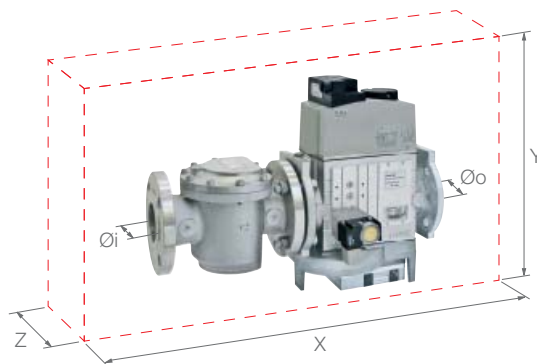

Example of gas train "COMPOSED" type without seal control

	NAME	CODE	Ø i	Ø o	X mm	Y mm	Z mm	SEAL CONTROL
MULTIBLOC GAS TRAINS	MBC 1200 SE 50	3970221	2"	2"	573	424	161	accessory
	MBC 1200 SE 50 CT	3970225	2"	2"	573	424	290	incorporated
COMPOSED GAS TRAINS	MBC 1900 SE 65 FC	3970222	DN 65	DN 65	583	430	237	accessory
	MBC 1900 SE 65 FC CT	3970226	DN 65	DN 65	583	430	300	incorporated
	MBC 3100 SE 80 FC	3970223	DN 80	DN 80	633	500	240	accessory
	MBC 3100 SE 80 FC CT	3970227	DN 80	DN 80	633	500	320	incorporated
	MBC 5000 SE 100 FC	3970224	DN 100	DN 100	733	576	350	accessory
	MBC 5000 SE 100 FC CT	3970228	DN 100	DN 100	733	576	350	incorporated

PRESSURE DROP DIAGRAM

The diagrams indicate the minimum pressure drop of the burners with the various gas trains that can be matched with them; at the value of these pressure drop add the combustion chamber pressure.

The value thus calculated represents the minimum required input pressure to the gas train.

The minimum input gas pressure required is 15 mbar while burner operating.

In particular, the pressure difference between gas train upstream and downstream has to remain always over pressure drop values indicated below.

RS 300/M BLU (NATURAL GAS)

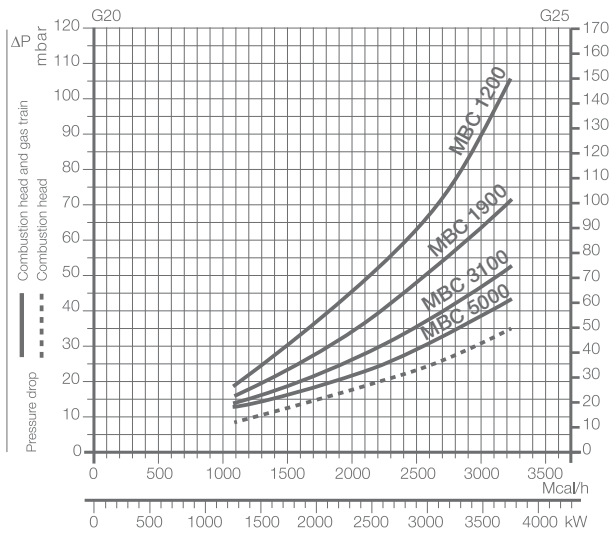

RS 400/M BLU (NATURAL GAS)

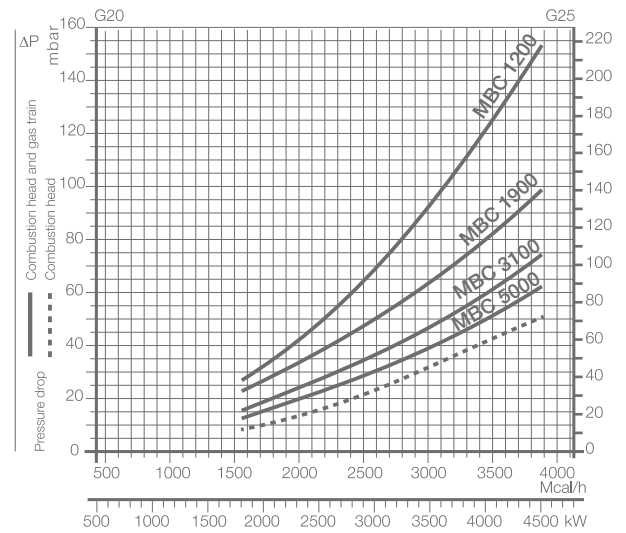

GAS TRAIN	CODE	ADAPTER	SEAL CONTROL
MBC 1200 SE 50	3970221	3000826 (I)	accessory
MBC 1200 SE 50 CT	3970225	3000826 (I)	incorporated
MBC 1900 SE 65 FC	3970222	3010221 (I)	accessory
MBC 1900 SE 65 FC CT	3970226	3010221 (I)	incorporated
MBC 3100 SE 80 FC	3970223	3010222 (I)	accessory
MBC 3100 SE 80 FC CT	3970227	3010222 (I)	incorporated
MBC 5000 SE 100 FC	3970224	3010223 (I)	accessory
MBC 5000 SE 100 FC CT	3970228	3010223 (I)	incorporated

GAS TRAIN	CODE	ADAPTER	SEAL CONTROL
MBC 1200 SE 50	3970221	3000826 (I)	accessory
MBC 1200 SE 50 CT	3970225	3000826 (I)	incorporated
MBC 1900 SE 65 FC	3970222	3010221 (I)	accessory
MBC 1900 SE 65 FC CT	3970226	3010221 (I)	incorporated
MBC 3100 SE 80 FC	3970223	3010222 (I)	accessory
MBC 3100 SE 80 FC CT	3970227	3010222 (I)	incorporated
MBC 5000 SE 100 FC	3970224	3010223 (I)	accessory
MBC 5000 SE 100 FC CT	3970228	3010223 (I)	incorporated

(I): adapter type "I" (see Gas Train Accessories paragraph).

RS 500/M BLU (NATURAL GAS)

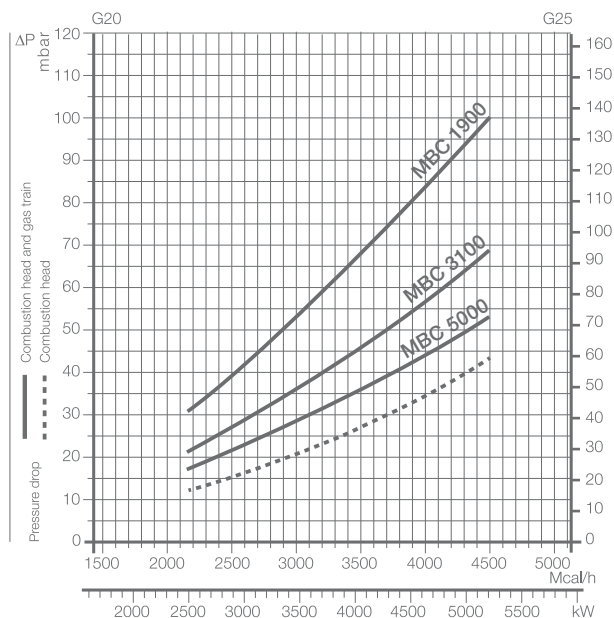

GAS TRAIN	CODE	ADAPTER	SEAL CONTROL
MBC 1900 SE 65 FC	3970222	3010221 (I)	accessory
MBC 1900 SE 65 FC CT	3970226	3010221 (I)	incorporated
MBC 3100 SE 80 FC	3970223	3010222 (I)	accessory
MBC 3100 SE 80 FC CT	3970227	3010222 (I)	incorporated
MBC 5000 SE 100 FC	3970224	3010223 (I)	accessory
MBC 5000 SE 100 FC CT	3970228	3010223 (I)	incorporated

(I): adapter type "I" (see Gas Train Accessories paragraph).

Please contact the Riello Burner Technical Office for different pressure levels from those above indicated and refer to the technical manual for the correct choice of the spring.

MBC 1200 gas train: the minimum operating pressure (*) is higher or equal to 10 mbar. The gas train has to be installed next to the burner (if needed, only with the adapters listed in the catalogue) and it has to operate in its own working field.

MBC 1900-3100-5000 gas train: the minimum operating pressure (*) is higher or equal to 15 mbar. The gas train has to be installed next to the burner (if needed, with the adapters listed in the catalogue) and it has to operate in its own working field.

(*) it is the upstream gas train pressure in full load operation conditions.

RS 800/M BLU (NATURAL GAS)

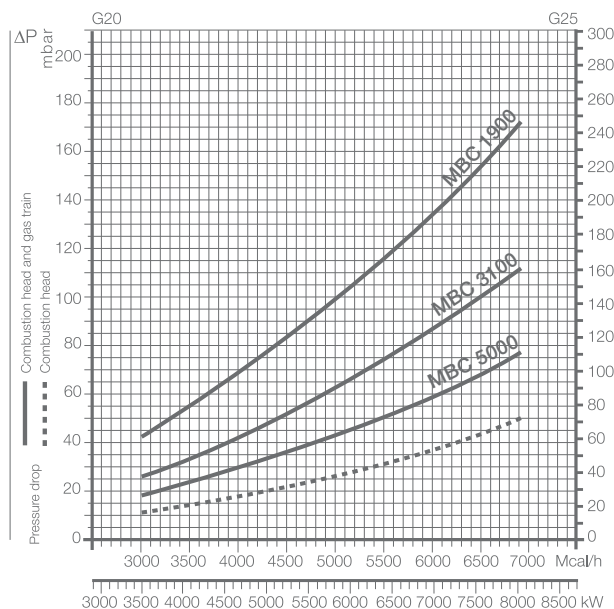

GAS TRAIN	CODE	ADAPTER	SEAL CONTROL
MBC 1900 SE 65 FC	3970222	3010221 (I)	accessory
MBC 1900 SE 65 FC CT	3970226	3010221 (I)	incorporated
MBC 3100 SE 80 FC	3970223	3010222 (I)	accessory
MBC 3100 SE 80 FC CT	3970227	3010222 (I)	incorporated
MBC 5000 SE 100 FC	3970224	3010223 (I)	accessory
MBC 5000 SE 100 FC CT	3970228	3010223 (I)	incorporated

SELECTING THE FUEL SUPPLY LINES

The following diagram enables pressure drop in a pre-existing gas line to be calculated and to select the correct gas train.

The diagram can also be used to select a new gas line when fuel output and pipe length are known. The pipe diameter is selected on the basis of the desired pressure drop. The diagram uses methane gas as reference; if another gas is used, conversion coefficient and a simple formula (on the diagram) transform the gas output to a methane equivalent (refer to figure A). Please note that the gas train dimensions must take into account the back pressure of the combustion chamber during operations.

Control of the pressure drop in an existing gas line or selecting a new gas supply line.

The methane output equivalent is determined by the formula fig. A on the diagram and the conversion coefficient.

Once the equivalent output has been determined on the delivery scale (\dot{V}), shown at the top of the diagram, move vertically downwards until you cross the line that represents the pipe diameter; at this point, move horizontally to the left until you meet the line that represents the pipe length.

Once this point is established you can verify, by moving vertically downwards, the pipe pressure drop of on the bottom scale below (mbar).

By subtracting this value from the pressure measured on the gas

meter, the correct pressure value will be found for the choice of gas train.

Example:

- gas used	G25
- gas output	9.51 mc/h
- pressure at the gas meter	20 mbar
- gas line length	15 m
- conversion coefficient	0.62 (see figure A)

- equivalent methane output $\dot{V} = \left[\begin{matrix} 9.51 \\ 0.62 \end{matrix} \right] = 15.34 \text{ mc/h}$

- once the value of 15.34 has been identified on the output scale (\dot{V}), moving vertically downwards you cross the line that represents 1" 1/4 (the chosen diameter for the piping);
- from this point, move horizontally to the left until you meet the line that represents the length of 15 m of the piping;
- move vertically downwards to determine a value of 1.4 mbar in the pressure drop bottom scale;
- subtract the determined pressure drop from the meter pressure, the correct pressure level will be found for the choice of gas train;

- correct pressure = (20-1.4) = 18.6 mbar

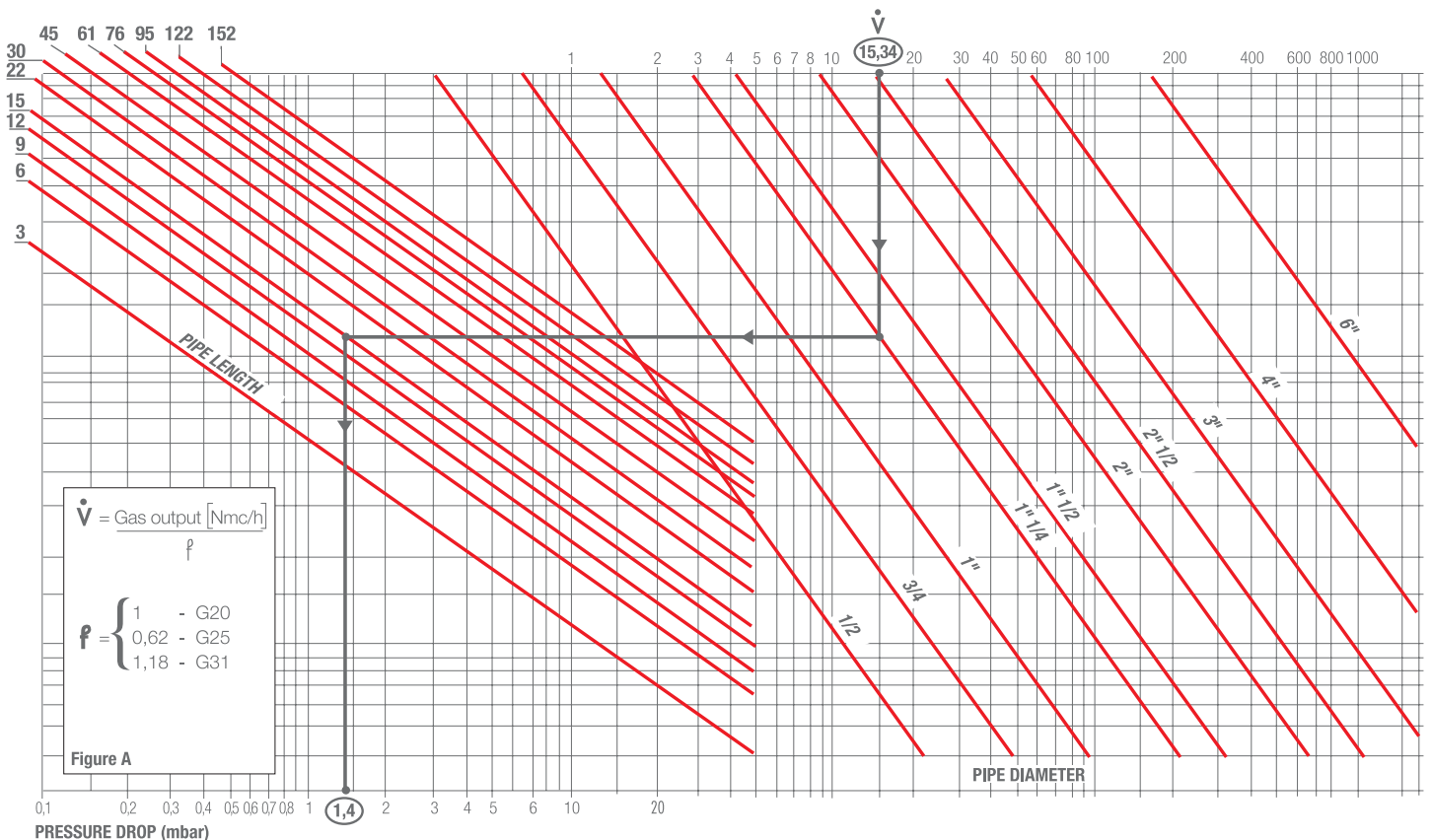

Ventilation

The ventilation unit comes with a sound proofing radial regulating system. All the burners in the RS 300-400-500-800/M BLU series are fitted with fans with reverse curve blades, which give excellent performance and are fitted in line with the combustion head. The air flow and sound-deadening materials used in the construction are designed to reduce sound emissions to the minimum and guarantee high levels of performance in terms of output and air pressure. A high precision servomotor through the main management module installed on each burner of RS 300-400-500-800/M BLU series, controls the air dampers position constantly.



Example of a sound proofing radial regulating system.

Combustion Head

The innovative combustion head adjustment system ensures perfect movement during modulation as well as reducing noise and pollutants. Simple adjustment of the combustion head allows to adapt internal geometry of the head to the output of the burner. The same adjustment servomotor for the air damper also varies, depending on the required output, the setting of the combustion head, through a simple lever. This system guarantees excellent mix on all firing rates range.



Example of a RS 500/M BLU burner combustion head.

DIMENSIONS OF THE FLAME

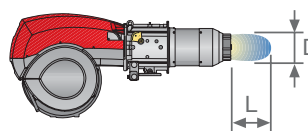
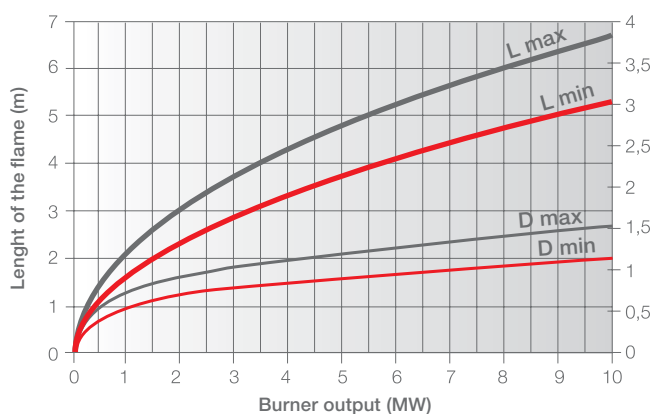

Example:
 Burner thermal output = 6000 kW;
 L_{flame} (m) = 4,7 m (medium value);
 D_{flame} (m) = 1,2 m (medium value)



Operation

BURNER OPERATION MODE

The RS 300-400-500-800/M BLU series of burners can have “two-stage progressive” or “modulating” operation.



Output regulator.



Analog 4÷20 mA or 0÷10 converter for remote modulation.

On “two-stage progressive” operation, the burner gradually adapts the output to the requested level, by varying between two pre-set levels (see picture A).

On “modulating” operation, normally required in steam generators, in superheater boilers or diathermic oil burners, a specific regulator and probes are required. These are supplied as accessories that must be ordered separately. The burner can work for long periods at intermediate output levels (see picture B).

“TWO-STAGE PROGRESSIVE” OPERATION

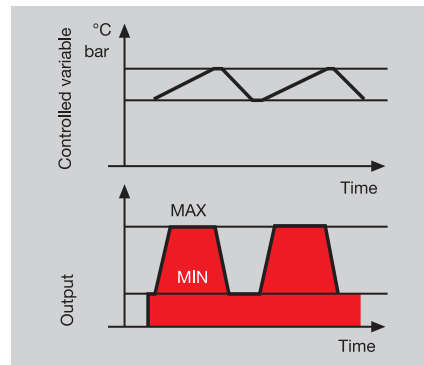

Picture A

“MODULATING” OPERATION

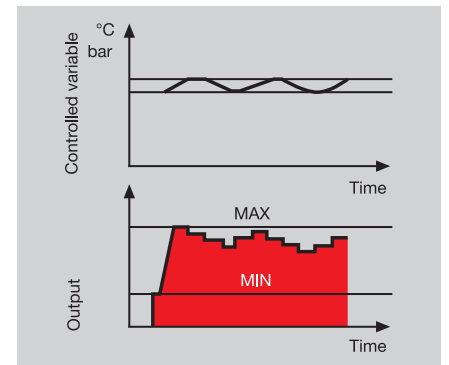

Picture B

All RS 300-400-500-800/M BLU series burners are fitted with a new microprocessor control panel for the supervision during intermittent operation.

For helping the commissioning and maintenance work, there are two main elements:



The lock-out reset button is the central **operating element** for resetting the burner control and for activating / deactivating the diagnostic functions.

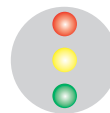

The multi-color LED is the central **indication element** for visual diagnosis and interface diagnosis.

Both elements are located under the transparent cover of lock-out reset button, as showed below.



There are two diagnostic choices, for indication of operation and diagnosis of fault cause:

VISUAL DIAGNOSIS

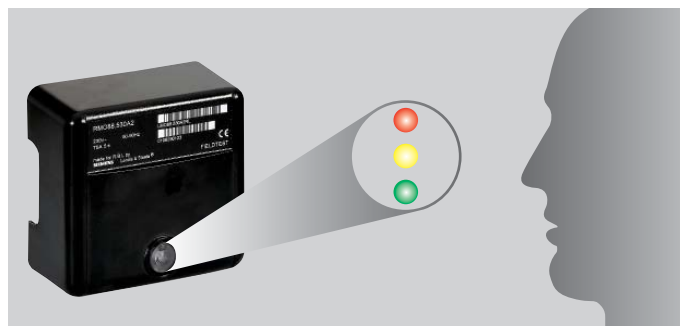

INTERFACE DIAGNOSIS

By the interface adapter and a PC with dedicated software or by a predisposed flue gas analyzer (see paragraph accessories).

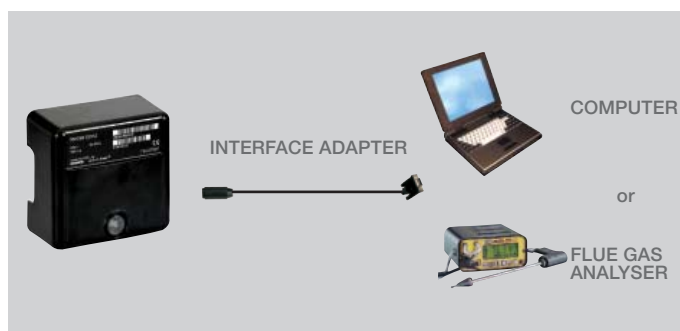

INDICATION OF OPERATION

In normal operation, the various status are indicated in the form of colour codes according to the table below.

The interface diagnosis (with adapter) can be activated by pressing the lock-out button for > 3 seconds.

COLOR CODE TABLE	
Operation status	Color code table
Stand-by	● ● ● ● ● ● ● ●
Pre-purging	● ● ● ● ● ● ● ●
Ignition phase	● ● ● ● ● ● ● ●
Flame OK	● ● ● ● ● ● ● ●
Poor flame	● ● ● ● ● ● ● ●
Undervoltage, built-in fuse	● ● ● ● ● ● ● ●
Fault, alarm	● ● ● ● ● ● ● ●
Flame simulation	● ● ● ● ● ● ● ●

● LED off

DIAGNOSIS OF FAULT CAUSES

After lock-out has occurred, the red signal lamp is steady on. In this status, the visual fault diagnosis according to the error code table can be activated by pressing the lock-out reset button for > 3 seconds.

The interface diagnosis (with adapter) can be activated by pressing again the lock-out button for > 3 seconds.

The flashing of red LED are a signal with this sequence:

(e.g. signal with n° 3 flashes – faulty air pressure monitor)



ERROR CODE TABLE

POSSIBLE CAUSE OF FAULT	FLASH CODE
No establishment of flame at the end of safety time: <ul style="list-style-type: none"> - faulty or soiled fuel valves - faulty or soiled flame detector - poor adjustment of burner, no fuel - faulty ignition equipment 	● 2x flashes
Faulty air pressure monitor	● 3x flashes
Extraneous light or simulation of flame on burner start up	● 4x flashes
Loss of flame during operation: <ul style="list-style-type: none"> - faulty or soiled fuel valves - faulty or soiled flame detector - poor adjustment of burner 	● 7x flashes
Wiring error or internal fault	● 10x flashes

START UP CYCLE

RS 300-400-500-800/M BLU

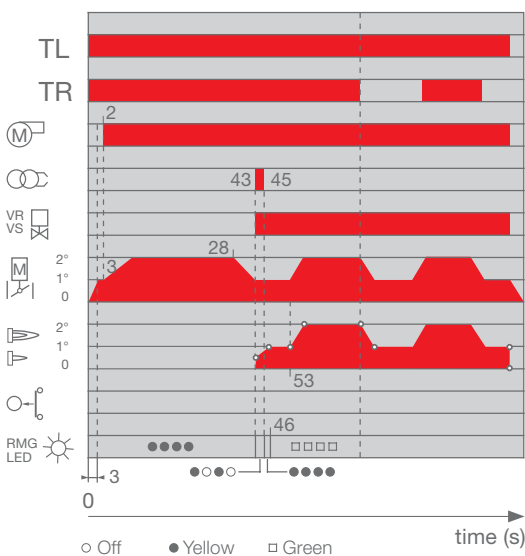

- 0 s The burner begins the firing cycle.
- 2 s The motor starts: pre-purge phase.
- 43 s Ignition electrode sparks; safety valve VS and adjustment valve VR open.
- 45 s The spark goes out.
- 53 s Output can be increased; start up cycle is concluded.

Wiring Diagrams



Electrical connections must be made by qualified and skilled personnel, according to the local norms.

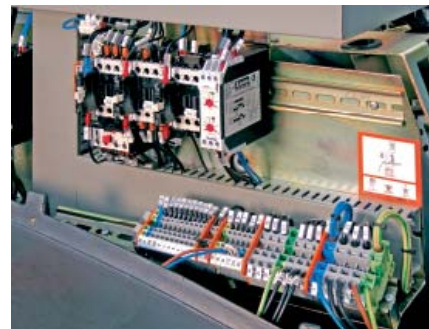

Example of the terminal board for electrical connections on RS/M BLU.

THREE PHASE SUPPLY AND GAS TRAIN CONNECTIONS

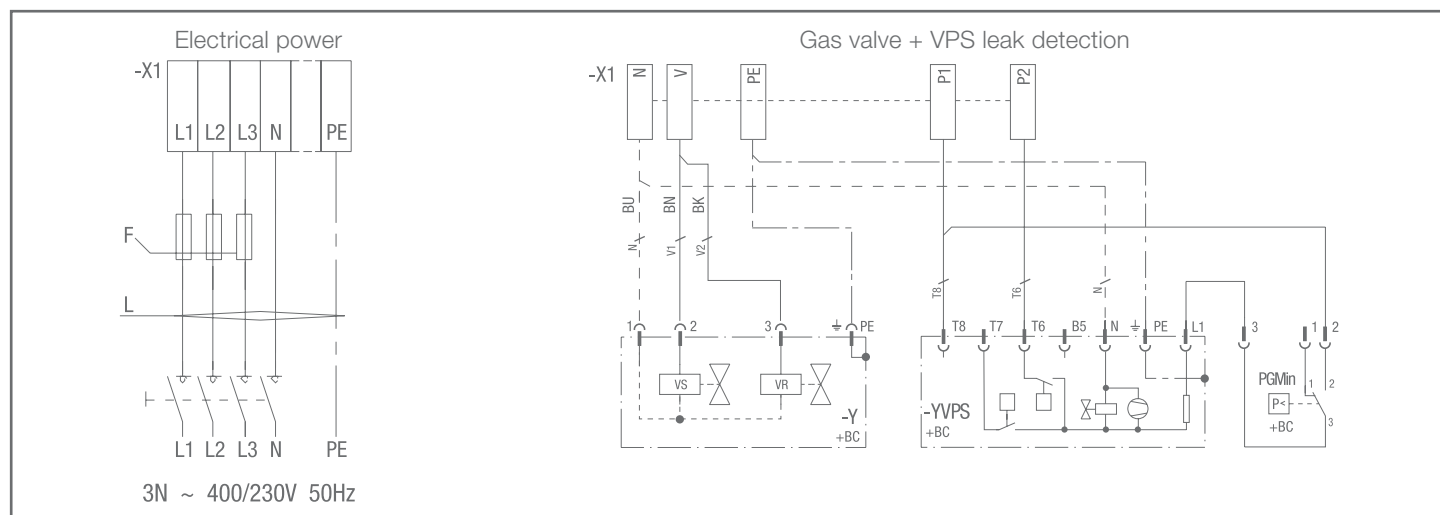

OUTPUT / INPUT CONNECTIONS

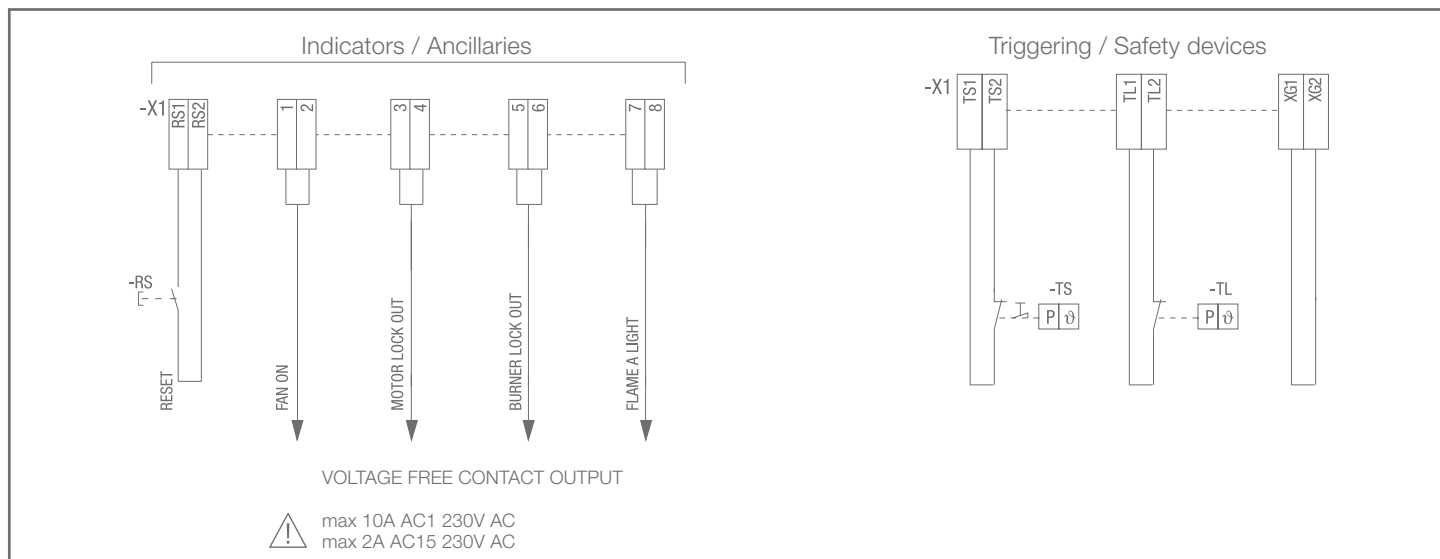

INPUT CONNECTIONS

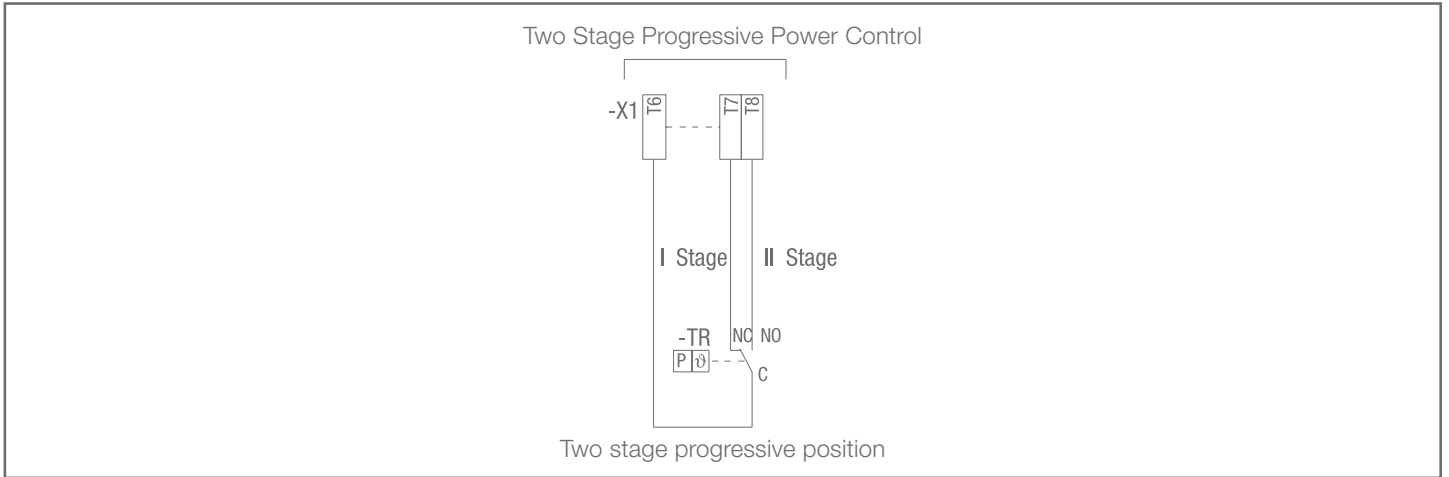

OPTIONAL CONNECTIONS

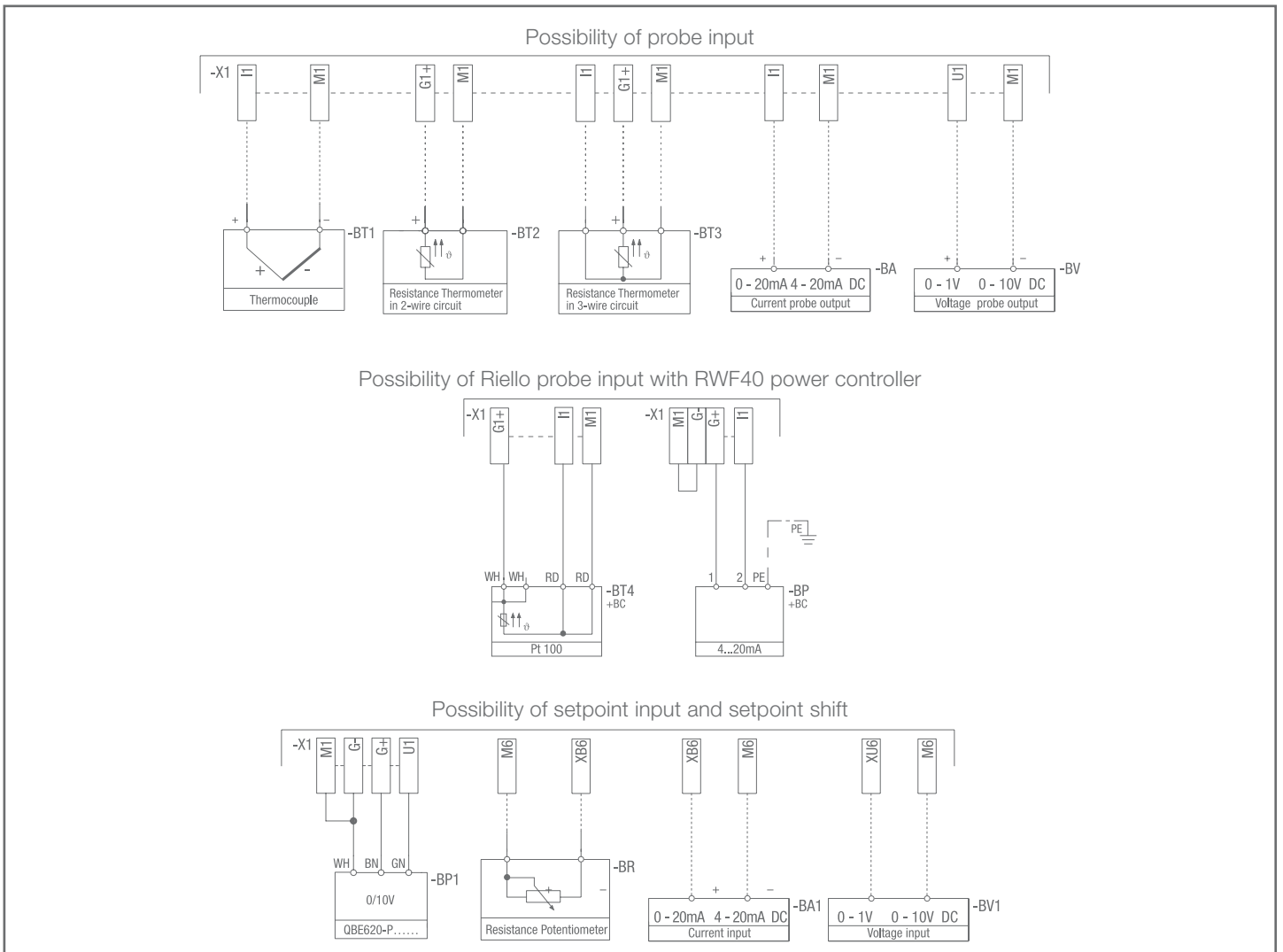

OPTIONAL CONNECTIONS

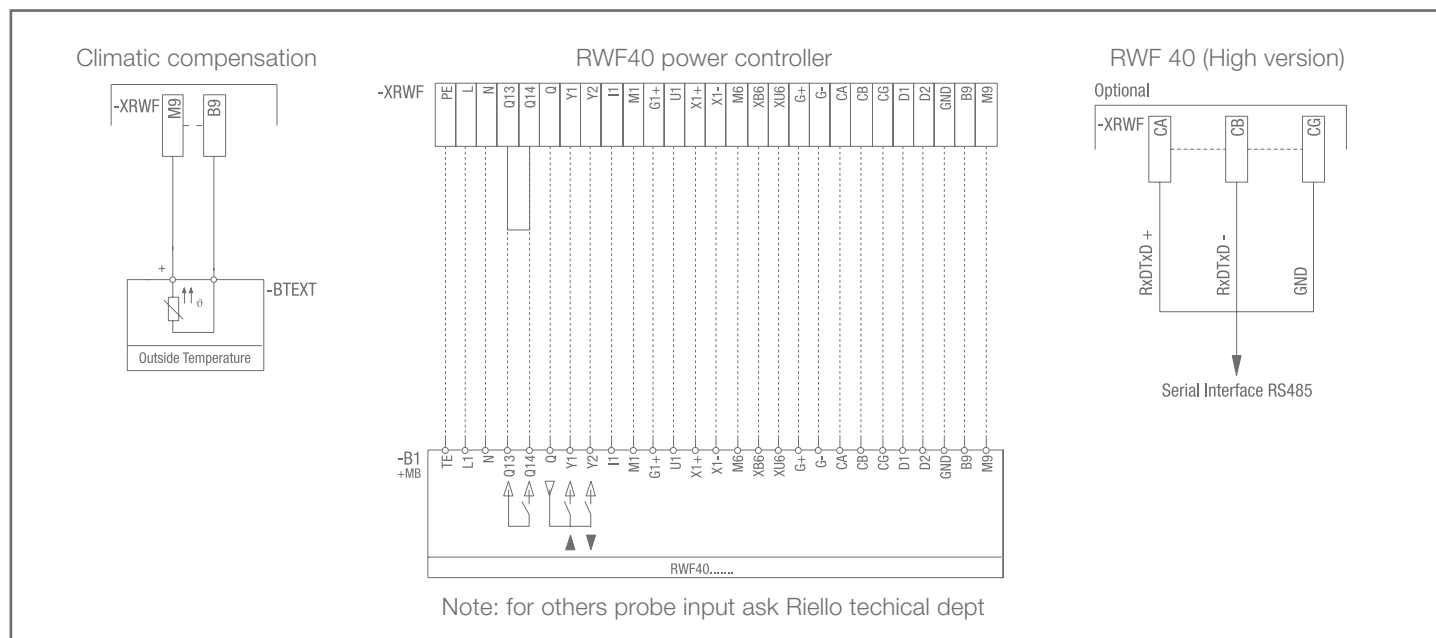

BA	DC input 0...20 mA, 4...20 mA
BA1	DC input 0...20 mA, 4...20 mA for modifying the setpoint
BA2	Load indicator
B1	RWF 40 power controller
BP	Pressure probe
BP1	Pressure probe
BR	Resistance potentiometer for modifying the setpoint
BT1	Thermocouple probe
BT2	Probe Pt 100 with 2 wires
BT3	Probe Pt 100 with 3 wires
BT4	Probe Pt 100 with 3 wires
BTEXT	External probe for the climatic compensation of the setpoint

BV	DC voltage input 0...1 V, 0...10 V
BV1	DC voltage input 0...1 V, 0...10 V for modifying the setpoint
PGMin	Minimum gas pressure switch
PGVP	Gas pressure switch for leak detection control device
RS	Remote lock-out reset button
TL	Load limit remote control system
TR	High-low mode load remote control system
TS	Safety control device system
X1	Main terminal strip
X2	RWF 40 power controller terminal strip
Y	Gas adjustment valve + gas safety valve
YPS	Seal control

The following table shows the supply lead sections and the type of fuse to be used.

MODEL	F (A)	L (mm ²)
▶ RS 300/M BLU	12 aM	4
▶ RS 400/M BLU	20 aM	6

MODEL	F (A)	L (mm ²)
▶ RS 500/M BLU	25 aM	6
▶ RS 800/M BLU	50 aM	10

F = Fuse L = Lead section

Emissions

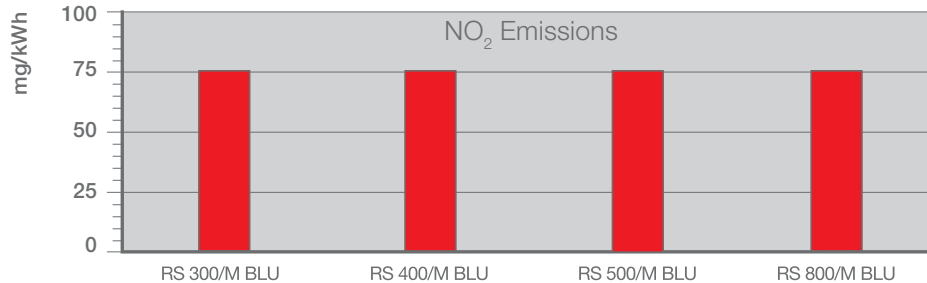

The noise emissions have been measured at the maximum output.

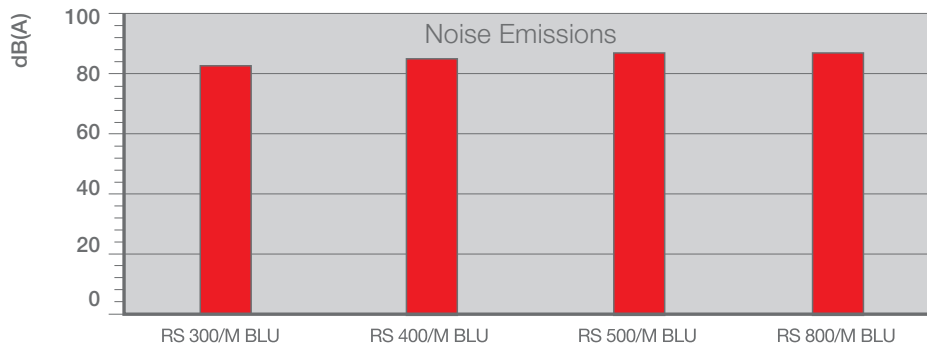

The RS/M BLU series reduces polluting emissions with its exclusive design which optimises air/fuel mixture. The gas in the combustion head is distributed through openings which are perpendicular to the air flow; part of the fuel is injected directly into the centre of the flame. This results in low flame temperature combustion to prevent the formation of NO. Gradual and progressive combustion throughout the flame prevents areas of high oxidation inside the flame. Emissions are further reduced by the re-circulation of combustion gases due to the high velocity of air leaving the combustion head. Pollution levels are below even the most severe standard requirements.

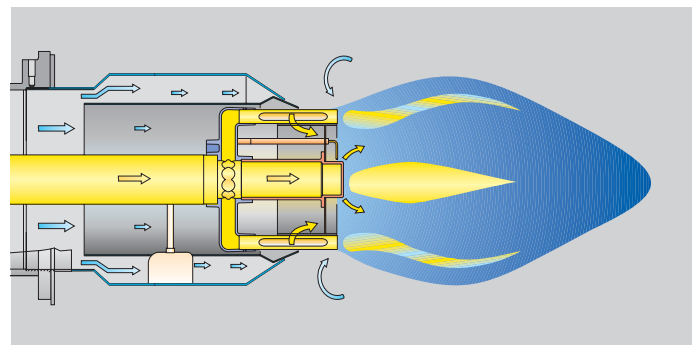

Overall Dimensions (mm)



BURNERS

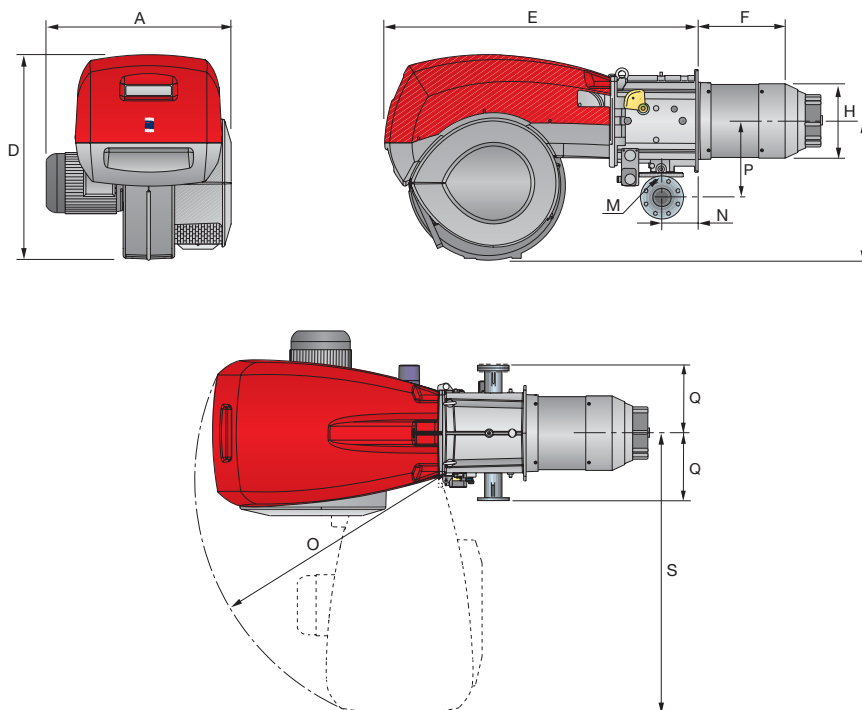

MODEL	A	D	E	F	H	I	M	N	O	P	Q	S
▶ RS 300/M BLU	720	867	1325	373	370	588	DN80	164	1055	342	320	1175
▶ RS 400/M BLU	775	867	1325	373	370	588	DN80	164	1055	342	320	1175
▶ RS 500/M BLU	775	867	1325	357	370	588	DN80	164	1055	342	320	1175
▶ RS 800/M BLU	940	867	1325	418	363	588	DN80	164	1055	427	320	1175

BURNER - BOILER MOUNTING FLANGE

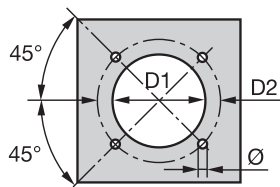

MODEL	D1	D2	Ø
▶ RS 300/M BLU	400	452	M18
▶ RS 400/M BLU	400	452	M18
▶ RS 500/M BLU	400	452	M18
▶ RS 800/M BLU	400	495	M18

PACKAGING

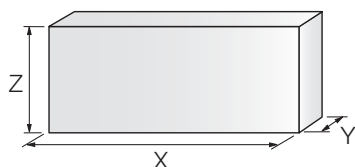

MODEL	X	Y	Z	kg
▶ RS 300/M BLU	1960	970	940	225
▶ RS 400/M BLU	1960	970	940	236
▶ RS 500/M BLU	1960	970	940	250
▶ RS 800/M BLU	2035	1090	1195	300

Burner Accessories

Accessories for modulating operation

POWER CONTROLLER



To obtain modulating operation, the RS/M BLU series of burners requires a regulator with three point outlet controls. The following table lists the accessories for modulating operation with their application range.

BURNER	TYPE	CODE
	RWF 40 - Basic version with 3 position output	3010356
► RS 300-400-500-800/M BLU	RWF 40 - High version with additional modulating output and RS 485 Interface	3010357

PROBE



The relative temperature or pressure probes fitted to the power controller must be chosen on the basis of the application.

BURNER	TYPE	RANGE (°C) (bar)	CODE
	Temperature PT 100	-100 ÷ 500°C	3010110
► RS 300-400-500-800/M BLU	Pressure 4 ÷ 20 mA	0 ÷ 2,5 bar	3010213
	Pressure 4 ÷ 20 mA	0 ÷ 16 bar	3010214

ANALOG CONTROL SIGNAL CONVERTER



BURNER	TYPE (INPUT SIGNAL)	CODE
► RS 300-400-500-800/M BLU	0/2 - 10 V (impedance 200 KΩ) 0/4 - 20 mA (impedance 250 Ω)	3010390

POTENTIOMETER



BURNER	KIT CODE
► RS 300-400-500-800/M BLU	3010402

It is necessary for analogic control signal converter operation.

Continuous ventilation kit



If the burner requires continuous ventilation in the stages without flame, a special kit is available as given in the following table:

BURNER	KIT CODE
► RS 300-400-500-800/M BLU	3010094

UV cell kit



A UV cell is available for the supervision of the flame alternatively to ionisation probe for special applications.

BURNER	KIT CODE
► RS 300-400-500-800/M BLU	3010359

PC interface kit



To connect the flame control panel to a personal computer for the transmission of operation, fault signals and detailed service information, an interface adapter with PC software are available.

BURNER	KIT CODE
► RS 300-400-500-800/M BLU	3002719

Sound proofing box



If noise emission needs reducing even further, sound-proofing boxes are available, as given in the following table:

BURNER	BOX TYPE	AVERAGE NOISE REDUCTION [dB(A)](*)	BOX CODE
► RS 300-400-500-800/M BLU	C7	10	3010376

(*) according to EN 15036-1 standard

LPG kit



For burning LPG gas, a special kit is available to be fitted to the combustion head of the burner.

BURNER	CODE
► RS 300-400-500/M BLU	3010445 (*)
► RS 800/M BLU	in progress

(*) approval in progress.

Gas Train Accessories

Adapters



In certain cases, an adapter must be fitted between the gas train and the burner, when the diameter of the gas train is different from the set diameter of the burner.

Below are given the adapters than can be fitted on the various burners:

BURNER	GAS TRAIN	ADAPTER TYPE	DIMENSIONS	L mm	ADAPTER CODE
► RS 300-400-500-800/M BLU	MBC 1200 SE 50*	I	2"	300	3000826
	MBC 1900 SE 65 FC*	I	DN 65	400	3010221
	MBC 3100 SE 80 FC*	I	DN 80	400	3010222
	MBC 5000 SE 100 FC*	I	DN 100	400	3010223
	MBC 1900 SE 65 FC*	I	DN 65	10	3010369
	MBC 5000 SE 100 FC*	I	DN 100	50	3010370

* with and without seal control

Stabiliser spring



To vary the pressure range of the gas train stabilisers, accessory springs are available. The following table shows these accessories with their application range:

GAS TRAIN	SPRING	SPRING CODE
► MBC 1900 SE 65 FC (CT)* MBC 3100 SE 80 FC (CT)* MBC 5000 SE 100 FC (CT)*	White from 4 to 20 mbar	3010381
	Red from 20 to 40 mbar	3010382
	Black from 40 to 80 mbar	3010383
	Green from 80 to 150 mbar	3010384

* with and without seal control

Please refer to the technical manual for the correct choice of spring.

Seal control



BURNER	CODE
► RS 300-400-500-800/M BLU	3010125

Specification

DESIGNATION OF SERIES

A specific index guides your choice of burner from the various models available in the RS/M BLU series. Below is a clear and detailed specification description of the product.

Series: R											
Fuel:		S	Natural Gas								
		L	Light oil								
		LS	Light oil/Natural Gas								
		N	Heavy oil								
Size											
Setting :		/1	Single stage					/E	Electronic cam		
		/B	Two stage					/P	Proportioning air/gas valve		
		/M	Modulating - Mechanical cam					/EV	Electronic cam predisposed for variable speed (with inverter)		
Emission :		...	Class 1 EN267 - EN676								
		MZ	Class 2 EN267 - EN676								
		BLU	Class 3 EN267 - EN676								
		MX	Class 2 EN267 Class 3 EN676								
Head length:		TC	standard head								
		TL	extended head								
Flame control system:											
		FS1	Standard (1 stop every 24 h)								
		FS2	Continuous working (1 stop every 72 h)								
Electrical supply to the system:											
		1/230/50	1/230V/50Hz								
		3/230/50	3/230V/50Hz								
		3/400/50	3N/400V/50Hz								
		3/230-400/50	3/230V/50Hz - 3N/400V/50Hz								
		3/220/60	3/220V/60Hz								
		3/380/60	3N/380V/60Hz								
		3/220-380/60	3/220/60Hz - 3N/380V/60Hz								
Auxiliary voltage:											
		230/50-60	230V/50-60Hz								
		110/50-60	110V/50-60Hz								
R	S	500	/M	BLU	TC	FS1	3/230-400/50	230/50-60			
BASIC DESIGNATION											
EXTENDED DESIGNATION											

AVAILABLE BURNER MODELS

RS 300/M BLU	TC	FS1	3/230-400/50	230/50-60
RS 400/M BLU	TC	FS1	3/400/50	230/50-60
RS 500/M BLU	TC	FS1	3/400/50	230/50-60
RS 500/M BLU	TC	FS2	3/400/50	230/50-60
RS 800/M BLU	TC	FS1	3/400/50	230/50-60
RS 800/M BLU	TC	FS2	3/400/50	230/50-60

Other versions are available on request.

PRODUCT SPECIFICATION

Burner

Monoblock forced draught gas burner with modulating operation, fully automatic, made up of:

- Fan with reverse curve blades high performance with low sound emissions
- Air suction circuit lined with sound-proofing material
- Air damper for air setting controlled by a high precision servomotor
- Air pressure switch
- Fan starting motor at 2900 rpm, three-phase 230/400 - 400/690 V with neutral, 50 Hz
- Low emission combustion head, that can be set on the basis of required output, fitted with:
 - stainless steel end cone, resistant to corrosion and high temperatures
 - ignition electrodes
 - flame stability disk
- Maximum gas pressure switch, with pressure test point, for halting the burner in the case of over pressure on the fuel supply line
- Flame control panel for controlling the system safety (RMG/M for FS1 intermittent operation - LGK16 for FS2 continuous operation)
- Ionisation probe for flame detection
- Star/triangle starter for the fan motor (burners with motor electrical power $\geq 7,5$ kW)
- Main electrical supply terminal board
- Burner on/off switch
- Auxiliary voltage led signal
- Manual or automatic output increase/decrease switch
- Burner working led signal
- Contacts motor and thermal relay with release button
- Motor internal thermal protection
- Motor failure led signal
- Burner failure led signal and lighted release button
- Led signal for correct rotation direction of fan motor
- Emergency button
- Coded connection plugs-sockets
- Burner opening hinge
- Lifting rings
- IP 54 electric protection level
- Tee gas supply connector DN 80 for gas train connection (RS 300-400-500 models).

Gas train

Fuel supply line, in the MULTIBLOC configuration (for a diameter of 2") or COMPOSED configuration (from a diameter of DN 65 until a diameter of DN 100), fitted with:

- Filter
- Stabiliser
- Minimum gas pressure switch
- Safety valve
- Valve seal control (for output > 1200 kW)
- One stage working valve with ignition gas output regulator.

Conforming to:

- 89/336 (2004/108) EC directive (electromagnetic compatibility)
- 73/23 (2006/95) EC directive (low voltage)
- 90/396/EC directive (gas)
- EN 676 (gas burners).

Standard equipment:

- 1 flange gasket
- 8 screws for fixing the flange
- 1 thermal screen
- 4 screws for fixing the burner flange to the boiler
- Instruction handbook for installation, use and maintenance
- Spare parts catalogue
- Curve DN 80 for gas train connection (RS 800 model).

Available accessories to be ordered separately:

- RWF 40 power controller
- Temperature probe -100/+500 °C
- Pressure probe 0-2.5 bar
- Pressure probe 0-16 bar
- Analog control signal converter
- Potentiometer kit for servomotor
- Continuous ventilation kit
- UV cell kit
- PC interface kit
- Sound proofing box
- LPG kit
- Adapters
- Stabiliser spring
- Seal control.

RIELLO s.p.A.

Via Ing. Pilade Riello, 5
37045 Legnago (VR) Italy

Tel. +39.0442.630111 - Fax +39.0442.21980

www.rielloburners.com - info@rielloburners.com

Since the Company is constantly engaged in the production improvement, the aesthetic and dimensional features, the technical data, the equipment and the accessories can be changed.
This document contains confidential and proprietary information of RIELLO S.p.A. Unless authorised, this information shall not be divulged, nor duplicated in whole or in part.



Riello Burners is a brand of Riello Group.